

GM862 Family Hardware User Guide

For GM862-QUAD , GM862-QUAD-PY and GM862-GPS

1v0300794 Rev. 2 – 2011-09-15



Disclaimer

The information contained in this document is the proprietary information of Telit Communications S.p.A. and its affiliates ("TELIT").

The contents are confidential and any disclosure to persons other than the officers, employees, agents or subcontractors of the owner or licensee of this document, without the prior written consent of Telit, is strictly prohibited.

Telit makes every effort to ensure the quality of the information it makes available. Notwithstanding the foregoing, Telit does not make any warranty as to the information contained herein, and does not accept any liability for any injury, loss or damage of any kind incurred by use of or reliance upon the information.

Telit disclaims any and all responsibility for the application of the devices characterized in this document, and notes that the application of the device must comply with the safety standards of the applicable country, and where applicable, with the relevant wiring rules.

Telit reserves the right to make modifications, additions and deletions to this document due to typographical errors, inaccurate information, or improvements to programs and/or equipment at any time and without notice.

Such changes will, nevertheless be incorporated into new editions of this document.

Copyright: Transmittal, reproduction, dissemination and/or editing of this document as well as utilization of its contents and communication thereof to others without express authorization are prohibited. Offenders will be held liable for payment of damages. All rights are reserved.

Copyright © Telit Communications S.p.A. 2009.



Contents

1. INTRODUCTION.....	6
1.1. CONTACT INFORMATION, SUPPORT.....	7
1.2. DOCUMENT ORGANIZATION.....	8
1.3. TEXT CONVENTIONS.....	9
1.4. RELATED DOCUMENTS.....	9
1.5. DOCUMENT HISTORY.....	10
2. DIMENSIONS	11
3. INTERFACE CONNECTORS ON GM862	13
3.1. DESCRIPTION	13
3.2. CONNECTORS POSITION	13
3.3. BOARD TO BOARD CONNECTOR.....	14
3.4. MOLEX 52991-0508 (MALE) GM862 CONNECTOR PIN-OUT	15
3.5. ANTENNA CONNECTORS.....	17
4. ANTENNA	19
4.1. GSM ANTENNA REQUIREMENTS	19
4.2. GSM ANTENNA - INSTALLATION GUIDELINES.....	19
4.3. GPS ANTENNA REQUIREMENTS (ONLY FOR GM862-GPS)	20
4.4. GPS ANTENNA - INSTALLATION GUIDELINES	20
5. LOGIC LEVEL SPECIFICATIONS.....	21
5.1. RESET SIGNAL	21
6. HARDWARE COMMANDS.....	23
6.1. TURNING ON THE GM862.....	23
6.2. TURNING OFF THE GM862	26
6.3. RESETTING THE GM862.....	27
6.3.1. <i>Hardware Unconditional Shutdown for GM862-GPS.....</i>	<i>27</i>
6.3.2. <i>Hardware Unconditional Restart for GM862-QUAD/QUAD-PY.....</i>	<i>29</i>
7. POWER SUPPLY.....	32
7.1. POWER SUPPLY REQUIREMENTS	32
7.2. EMBODIED BATTERY CHARGER	35
7.3. GENERAL DESIGN RULES	36
7.3.1. <i>Electrical Design Guidelines.....</i>	<i>36</i>
7.3.1.1. +5V input Source Power Supply Design Guidelines.....	36
7.3.1.2. +12V Input Source Power Supply Design Guidelines.....	37
7.3.1.3. Battery Source Power Supply Design Guidelines	38
7.3.1.4. Battery Charge Control Circuitry Design Guidelines.....	39
7.3.2. <i>Thermal Design Guidelines.....</i>	<i>41</i>
7.3.3. <i>Power Supply PCB Layout Guidelines.....</i>	<i>42</i>
7.3.4. <i>Parameters for ATEX Application</i>	<i>44</i>
8. SERIAL PORTS	45



8.1.	GM862-GPS SERIAL PORTS	45
8.2.	GM862-QUAD/ QUAD-PY SERIAL PORTS	45
8.3.	MODEM SERIAL PORT	45
8.4.	GPS SERIAL PORT (GM862-GPS ONLY).....	48
8.5.	TRACE SERIAL PORT (GM862-QUAD-PY ONLY)	48
8.6.	LEVEL TRANSLATION	48
8.7.	5V UART LEVEL TRANSLATION	50
9.	AUDIO SECTION OVERVIEW	53
9.1.	SELECTION MODE	53
9.2.	ELECTRICAL CHARACTERISTICS.....	55
9.3.	INPUT LINES CHARACTERISTICS.....	55
9.4.	OUTPUT LINES CHARACTERISTICS	56
10.	GENERAL PURPOSE I/O	58
10.1.	GPIO LOGIC LEVELS.....	61
10.2.	USING A GPIO PIN AS INPUT	62
10.3.	USING A GPIO PIN AS OUTPUT.....	62
10.4.	USING THE RF TRANSMISSION CONTROL GPIO4	62
10.5.	USING THE RFTXMON OUTPUT GPIO5	62
10.6.	USING THE ALARM OUTPUT GPIO6	63
10.7.	USING THE BUZZER OUTPUT GPIO7	64
10.8.	MAGNETIC BUZZER CONCEPTS	65
10.8.1.	<i>Short Description.....</i>	<i>65</i>
10.8.2.	<i>Frequency Behavior.....</i>	<i>66</i>
10.8.3.	<i>Power Supply Influence.....</i>	<i>66</i>
10.8.4.	<i>Working Current Influence.....</i>	<i>66</i>
11.	ADC SECTION	67
11.1.	ADC CONVERTER.....	67
11.1.1.	<i>Description.....</i>	<i>67</i>
11.1.2.	<i>Using ADC Converter.....</i>	<i>67</i>
12.	INDICATION OF NETWORK SERVICE AVAILABILITY	68
13.	MOUNTING THE GM862 MODULE ON THE BOARD	69
13.1.	ANTENNA COAXIAL CABLE FIXING	70
13.2.	PRECAUTIONS.....	71
14.	CONFORMITY ASSESSMENT ISSUES	72
15.	SAFETY RECOMMENDATIONS	73



Chapter 12 “Network Service Availability”

Chapter 13: “Mounting the GM862 on the application board” Recommendations and specifics on how to mount the module on the user’s board.

Chapter 14 “Conformity Assessment Issues”

Chapter 15 “Safety Reccomendations”

1.3. Text Conventions



Danger – This information MUST be followed or catastrophic equipment failure or bodily injury may occur.



Caution or Warning – Alerts the user to important points about integrating the module, if these points are not followed, the module and end user equipment may fail or malfunction.



Tip or Information – Provides advice and suggestions that may be useful when integrating the module.

All dates are in ISO 8601 format, i.e. YYYY-MM-DD.

1.4. Related Documents

Telit GSM/GPRS Family Software User Guide, 1w0300784

Audio settings application note, 80000NT10007a

Digital voice Interface Application Note, 80000NT10004a

GM862 family Product description, 80272ST10019A

SIM Holder Design Guides, 80000NT10001a

AT Commands Reference Guide, 80000ST10025a



1.5. Document History

Revision	Date	Changes
ISSUE#0	2008-12-03	First Release
ISSUE#1	2009-12-16	Inserted Chapter 10.8 Added §7.2 Embodied battery charger Updated §3.4 : added DTR lines to those to be connected if not used. Updated chapter 9 Audio Section Updates all schematics Applied new layout Added flowcharts in on/off/reset procedures block Added DVI info in the pin out section Noted in the pin-out section about RTS in need of being connected to ground Updated Power consumption section
ISSUE#2	2011-09-15	Corrected pin 43 on table at page 17



2. Dimensions

The Telit GM862 module overall dimension are:

Length: 43.9 mm

Width: 43.9 mm

Thickness: 6.9 mm

Volume: $\cong 13 \text{ cm}^3$

The layout of the GM862-GPS module is shown in the following figure:

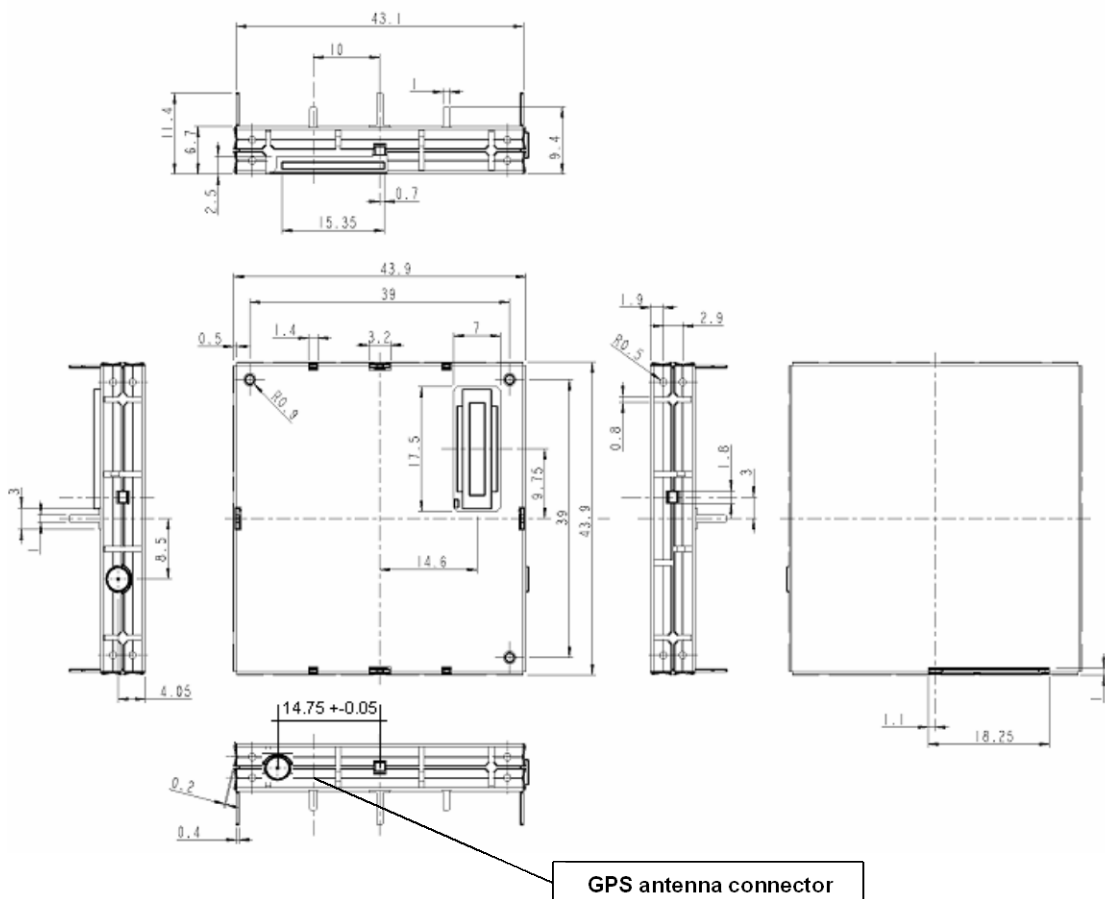

The layout of the GM862-QUAD/ QUAD-PY modules is shown in the following figure:

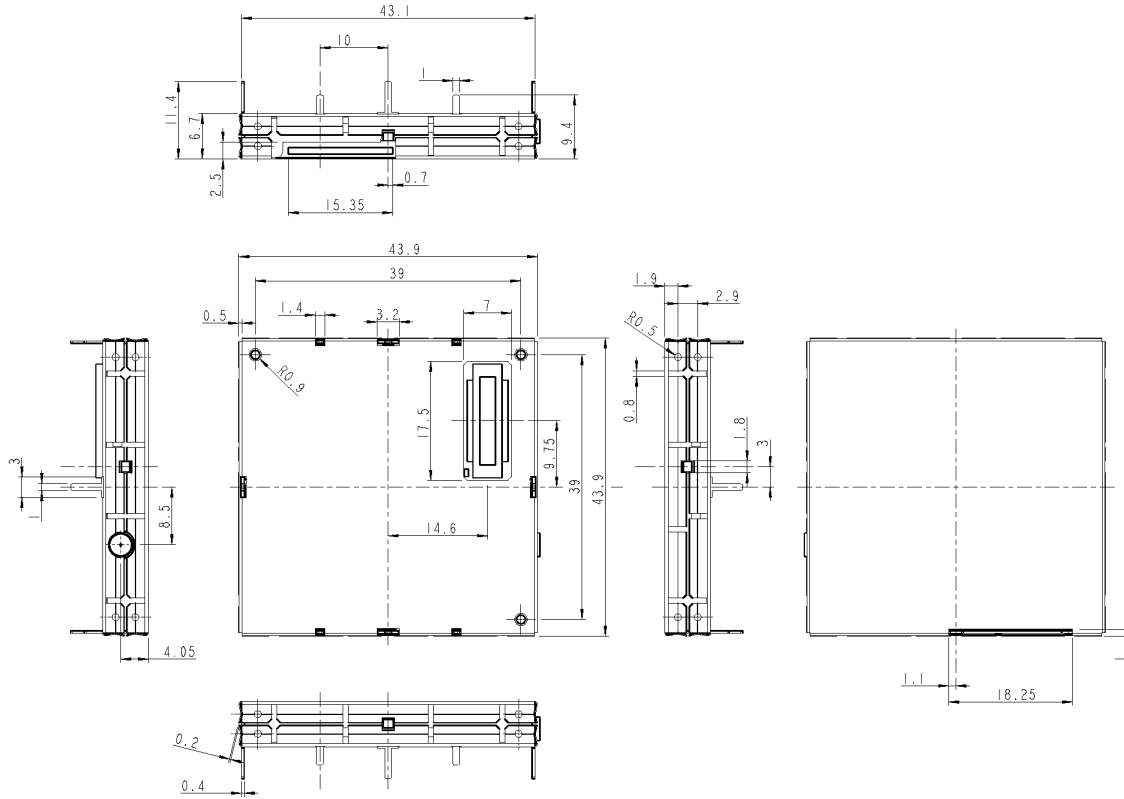

3. Interface Connectors on GM862

3.1. Description

The Telit GM862 is provided of the following interfaces:

- GSM antenna connector
- Board To Board Interface connector
- SIM Card Reader
 - GPS antenna connector (on GM862-GPS only)

The Telit GM862 board to board connector is a CSTP 50 pin vertical SMD Molex 52991-0508 (male).

3.2. Connectors Position

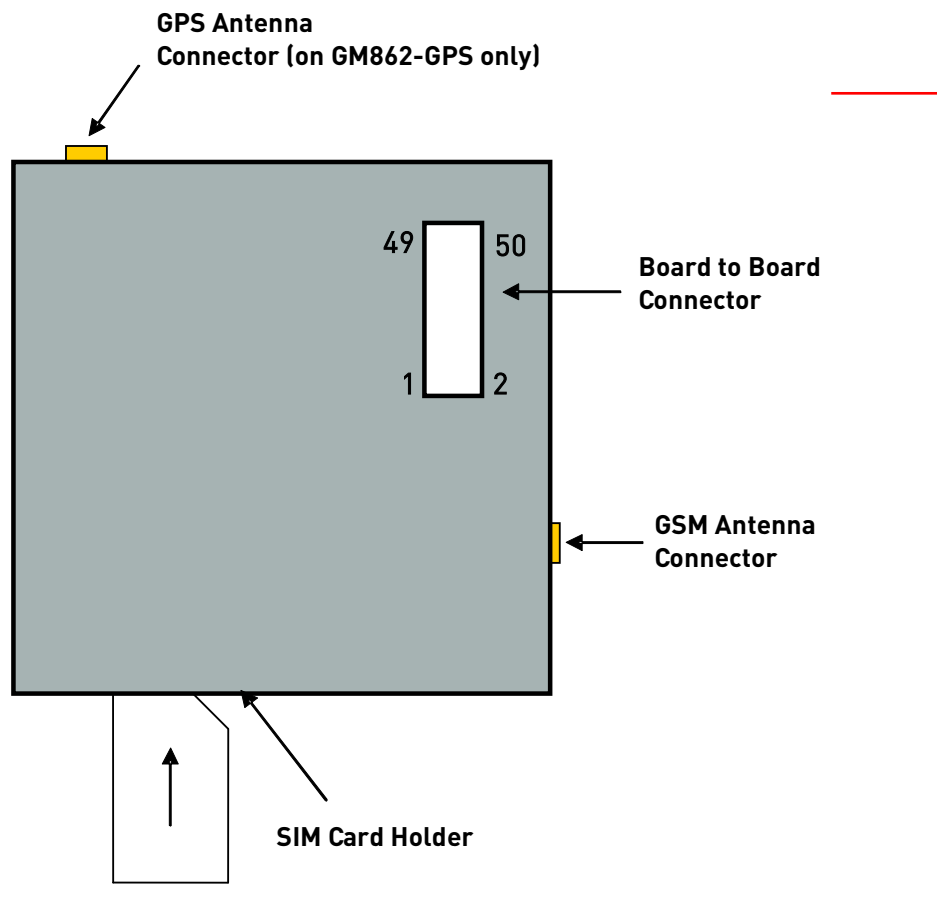

3.3. Board to Board Connector

Molex 52991-0508 (male) GM862 Connector LAY-OUT

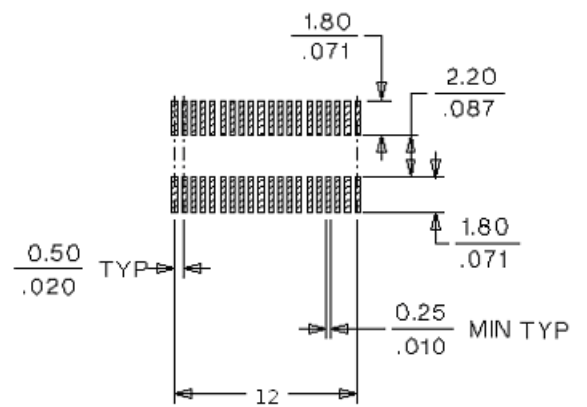
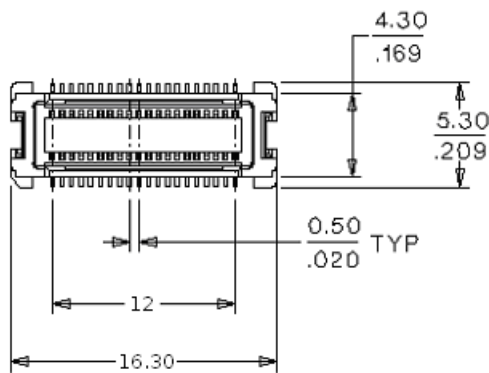
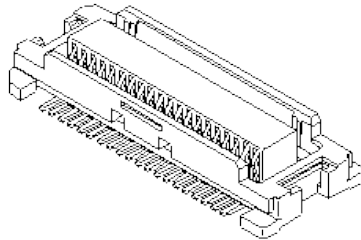

PCB LAYOUT: COMPONENT SIDE

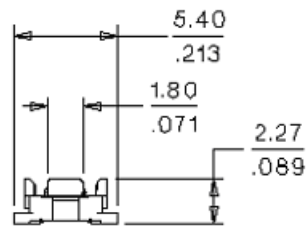

3.4. Molex 52991-0508 (male) GM862 Connector PIN-OUT

Pin	Signal	I/O	Function	Internal Pull up	Type
1	VBATT	-	Main power supply		Power
2	GND	-	Ground		Power
3	VBATT	-	Main power supply		Power
4	GND	-	Ground		Power
5	VBATT	-	Main power supply		Power
6	A/D	-	A/D converter @ 11 bit (Input Impedance >100Kohm)		Max 2V input
7	VBATT	-	Main power supply		Power
8	CHARGE	AI	Battery Charger Input		Power
9	EAR_HF+	A0	Handsfree ear output, phase +		Audio
10	EAR_MT-	A0	Handset earphone signal output, phase -		Audio
11	EAR_HF-	A0	Handsfree ear output, phase -		Audio
12	EAR_MT+	A0	Handset earphone signal output, phase +		Audio
13	MIC_HF-	AI	Handsfree microphone input; phase -		Audio
14	MIC_MT+	AI	Handset microphone signal input; phase+		Audio
15	MIC_HF+	AI	Handsfree microphone input; phase +		Audio
16	MIC_MT-	AI	Handset microphone signal input; phase-		Audio
17	ON_OFF	I	Input command for switching power ON or OFF (toggle command).	47KΩ	Pull Up to VBATT
18	AXE	I	Handsfree switching	100KΩ	CMOS 2.8V
19	SIMIO	I/O	External SIM signal - Data I/O		1.8 / 3V
20	C103/TXD	I	Serial data input (TXD) from DTE		CMOS 2.8V
21	PWRMON	O	Module Status ON indication (Signal output for power on/off control of external devices)	1KΩ	CMOS 2.8V
22	SIMVCC	-	External SIM signal – Power (3)		1.8 / 3V
23	RESET	I	Reset input		
24	SIMRST	O	External SIM signal – Reset		1.8 / 3V
25	RESERVED	-	RESERVED		-
26	SIMCLK	O	External SIM signal – Clock		1.8 / 3V
27	SIMIN	I/O	External SIM signal – Presence (active low)	47KΩ	CMOS 2.8V
28	GPO2 / JDR	O	General purpose output (Open Collector) / Jammer Detect Report		Open Collector
29	C106/CTS	O	Output for Clear to send signal (CTS) to DTE		CMOS 2.8V
30	C125/RING	O	Output for Ring indicator signal (RI) to DTE		CMOS 2.8V
31	GPI1	I	General purpose input		transistor base



Pin	Signal	I/O	Function	Internal Pull up	Type
32	GPI08	I/O	Configurable general purpose I/O pin		CMOS 2.8V
33	C107/DSR	0	Output for Data set ready signal (DSR) to DTE / DVI1_RX (only on GM862-QUAD-PY)		CMOS 2.8V
34	GPI09	I/O	Configurable general purpose I/O pin		CMOS 2.8V
35	TX_GPS	0	TX Data NMEA GPS protocol		CMOS 2.8V
36	C109/DCD	0	Output for Data carrier detect signal (DCD) to DTE		CMOS 2.8V
37	C104/RXD	0	Serial data output to DTE		CMOS 2.8V
38	GPI010/ CLK	I/O	Configurable general purpose I/O pin / Python DEBUG 4)		CMOS 2.8V
39	STAT_LED	0	Status indicator led		Open Collector
40	GPI011	I/O	Configurable general purpose I/O pin	4.7 K Ω	CMOS 2.8V
41	RX_GPS	I	RX Data NMEA GPS protocol		CMOS 2.8V
42	GPI012	I/O	Configurable general purpose I/O pin	47 K Ω	CMOS 2.8V
43	C108/DTR	I	Input for Data terminal ready signal (DTR) from DTE		CMOS 2.8V
44	GPI013 / MRST	I/O	Configurable general purpose I/O pin / Python DEBUG (4)		CMOS 2.8V
45	C105/RTS ¹	I	Input for Request to send signal (RTS) from DTE		CMOS 2.8V
46	GPI03	I/O	Configurable general purpose I/O pin / DVI1_TX (only on GM862-QUAD-PY)	47 K Ω	CMOS 2.8V
47	GPI04	I/O	Configurable general purpose I/O pin / TX Disable Control	4.7 K Ω	CMOS 2.8V
48	GPI05 / MTSR	I/O	Configurable general purpose I/O pin / Python DEBUG (4)		CMOS 2.8V
49	GPI06 / ALARM	I/O	Configurable general purpose I/O pin / ALARM		CMOS 2.8V
50	GPI07 / BUZZER	I/O	Configurable general purpose I/O pin / BUZZER		CMOS 2.8V

(1) For the exclusive use of the Technical Support Service

(2) An earphone with 150 ohm impedance can be directly connected to EAR+ and EAR-

(3) On this pin a maximum of 10nF bypass capacitor is allowed.

(4) This output requires an external circuit to connect it to a serial port.

¹ RTS should be connected to the GND (on the module side) if flow control is not used.



On GM862-QUAD and GM862-QUAD-PY the signals are defined as in the following table:

35	TX_TRACE	0	TX Data for Python Debug / DVI1_CLK (only on GM862-QUAD-PY)	CMOS 2.8V
38	GPIO10	I/O	Configurable general purpose I/O pin	CMOS 2.8V
41	RX_TRACE	1	RX Data for Python Debug / DVI1_WA (only on GM862-QUAD-PY)	CMOS 2.8V
44	GPIO13	I/O	Configurable general purpose I/O pin	CMOS 2.8V
48	GPIO5	I/O	Configurable general purpose I/O pin	CMOS 2.8V

If not used, almost all pins must be left disconnected. The only exceptions are the following pins:

pin	signal
1,3,5,7	VBATT
2,4,8	GND
17	ON/OFF*
20	TXD
23	RESET*
43	DTR(1)
37	RXD
45	RTS (2)

(1) DTR Lines should be set correctly (pull-up), since a transition of the DTR causes closing of multiplexer.

(2) RTS must be connected to the GND (on the module side) if flow control is not used

3.5. Antenna Connectors

The Telit GM862-GPS includes two 50 Ohm MMCX coaxial female RF connectors (only one in case of GM862-QUAD / QUAD-PY). On the user application side the following connector must be used:

Telegärtner MMCX Angle Plug Crimp - Order n. J01340A0121

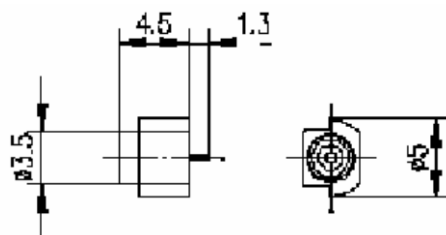

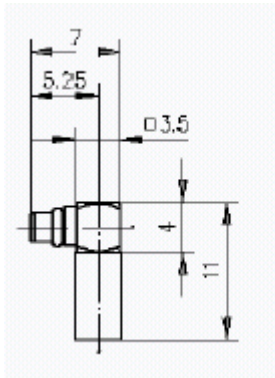

CAUTION:

Be very careful when connecting the Telit GM862 RF connector. The RF connector can be damaged if not connected with the proper antenna RF connector. The minimum number of insertion cycles are recommended.



4.3. GPS Antenna Requirements (only for GM862-GPS)

The GM862-GPS module is not provided with an internal LNA amplifier. The use of an active antenna is important to achieve a good performance.

The module is provided of an Antenna supply circuit with the following characteristics:

- Supply voltage referred to VBATT (3.4 to 4.2 V DC)
- Supply enable controlled internally by the BB
- Current measurement circuit (readable also with AT commands)
- Voltage measurement circuit (readable also with AT commands)
- HW Protection for Antenna Short Circuit (if consumption exceeds 40mA)

The external active antenna for a Telit GM862-GPS device shall fulfill the following requirements:

ANTENNA REQUIREMENTS	
Frequency range	1575.42 MHz (GPS L1)
Bandwidth	+ - 1.023 MHz
Gain	1.5 dBi < Gain < 4.5 dBi
Impedance	50 Ω
Amplification	Typical 25dB (max 27dB)
Supply voltage	Must accept from 3 to 5 V DC
Current consumption	Typical 20 mA (40 mA max)

Furthermore if the device is developed for the US market and/or Canada market, it shall comply to the FCC and/or IC approval requirements:

This device is to be used only for mobile and fixed application.

4.4. GPS Antenna - Installation Guidelines

The GM862-GPS due to its characteristics of sensitivity is capable to perform a Fix inside the buildings. (In any case the sensitivity could be affected by the building characteristics i.e. shielding.)

The Antenna must not be co-located or operating in conjunction with any other antenna or transmitter.

The antenna shall not be installed inside metal cases

The antenna shall be installed also according to the antenna manufacturer instructions.



6. Hardware Commands

6.1. Turning ON the GM862

To turn on the GM862 the pin ON# must be tied low for at least 1 second and then released.

The maximum current that can be drained from the ON# pin is 0,1 mA.

A simple circuit to do it is:

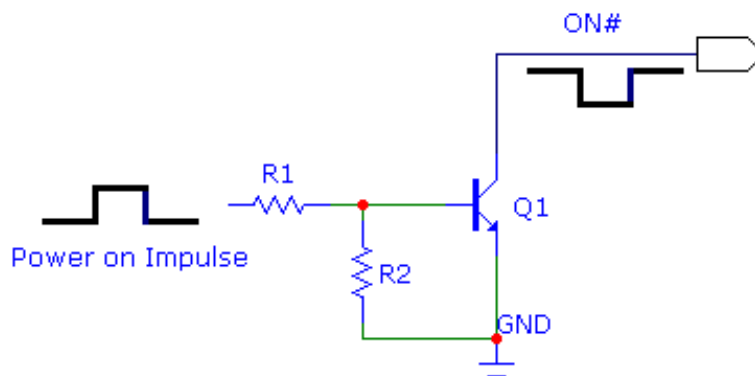

NOTE:

Do not use any pull up resistor on the ON# line, it is internally pulled up. Using pull up resistor may bring to latch up problems on the GM862 power regulator and improper power on/off of the module. The line ON# must be connected only in open collector configuration.

NOTE:

In this document all the lines that are inverted, hence have active low signals are labelled with a name that ends with a "#" or with a bar over the name.

NOTE:

The GM862 turns fully on also by supplying power to the Charge pad (Module provided with a battery on the VBATT pads).



TIP:

To check if the device has powered on, the hardware line PWRMON should be monitored. After 900ms the line raised up the device could be considered powered on.

PWRMON line rises up also when supplying power to the Charge pad



For example:

Let us assume you need to drive the ON# pin with a totem pole output of a +3/5 V microcontroller (uP_OUT1):

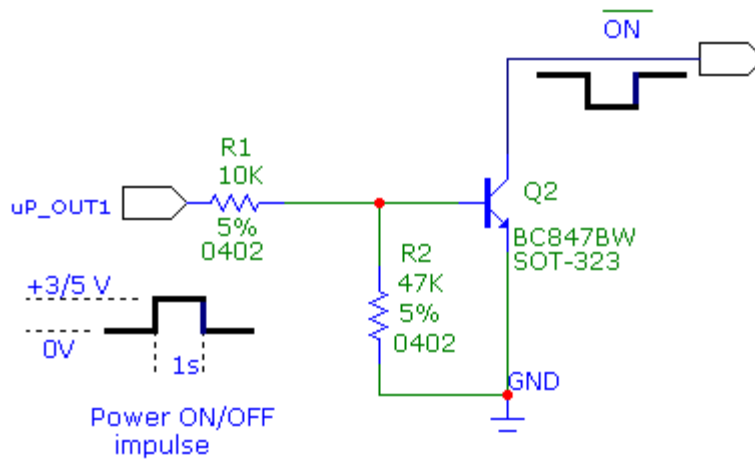

Let us assume you need to drive the ON# pin directly with an ON/OFF button:

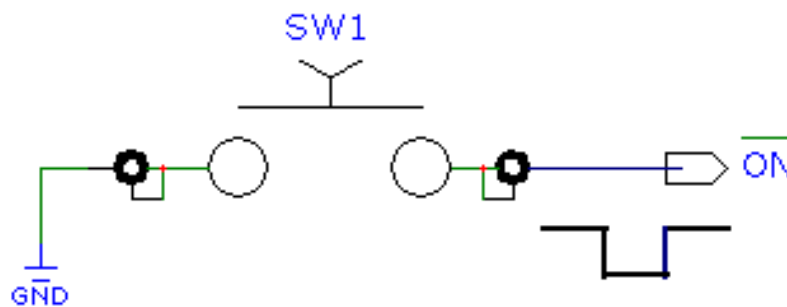

A flow chart with proper turn on procedure is detailed below:

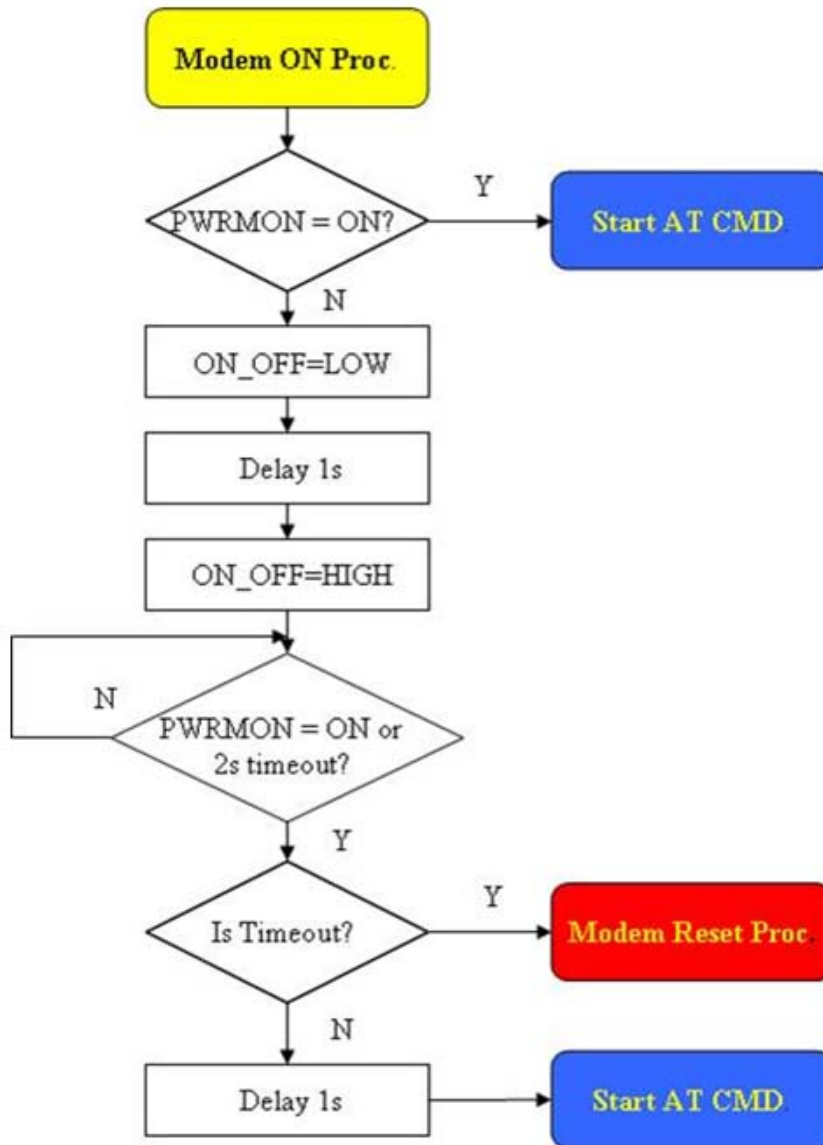

6.2. Turning OFF the GM862

The device can be turned off in the following ways:

- by software command (see GM862 Software User Guide, AT#SHDN)
- by tying low pin ON#

Either ways, the device issues a detach request to network informing that the device will not be reachable any more. The hardware unconditional shutdown described in par. 6.3 does not issue this request and shuts down the device immediately.

To turn OFF the GM862 via pin ON#, this must be tied low for at least 1s and then released.

The same circuitry and timing for the power on shall be used.

The device shuts down after the release of the ON# pin.

The following flow chart shows the proper turnoff procedure:

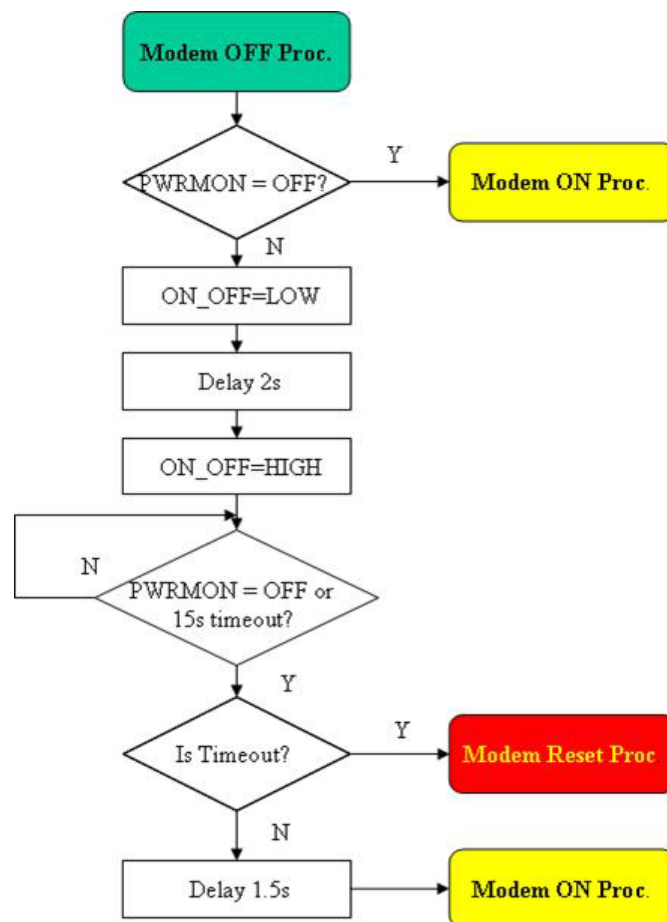



TIP:

To check if the device has powered off, the hardware line PWRMON must be monitored. When PWRMON goes low, the device has powered off.

6.3. Resetting the GM862



NOTE:

The concept of resetting the module differs from versions of the GM862. On GM862-QUAD/QUAD-PY modules, operating on the RESET# pin as described next will actually reboot the module, giving place to what we'll call an Hardware Unconditional Restart(par 6.3.2) , while on GM862-GPS it will shut the module down generating an Hardware Unconditional Shutdown (par .6.3.1).

6.3.1. Hardware Unconditional Shutdown for GM862-GPS



WARNING:

The hardware unconditional shutdown must not be used during normal operation of the device since it does not detach the device from the network. It shall be kept as an emergency exit procedure to be done in the rare case that the device gets stacked waiting for some network or SIM responses.

To unconditionally Shutdown the GM862-GPS the pin RESET# must be tied low for at least 200ms and then released.

The maximum current that can be drained from the RESET# pin is 0.15 mA.

A simple circuit to do it is:

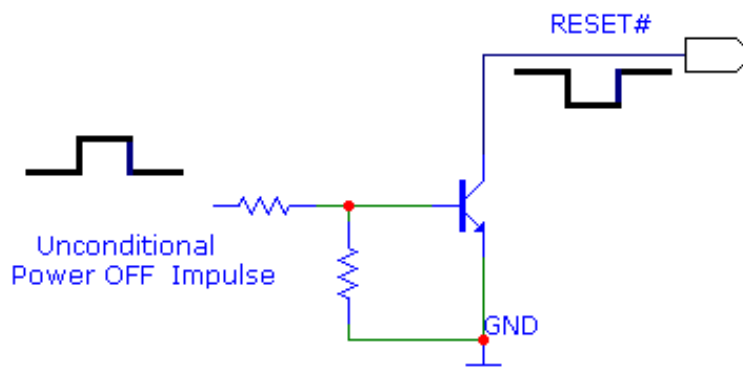



NOTE:

Do not use any pull up resistor on the RESET# line nor any totem pole digital output. Using pull up resistor may bring to latch up problems on the GM862 power regulator and improper functioning of the module. The line RESET# must be connected only in open collector configuration.



TIP:

The unconditional hardware reset must always be implemented on the boards and must be used by the software as an emergency exit procedure.

A flow chart for this is detailed below:

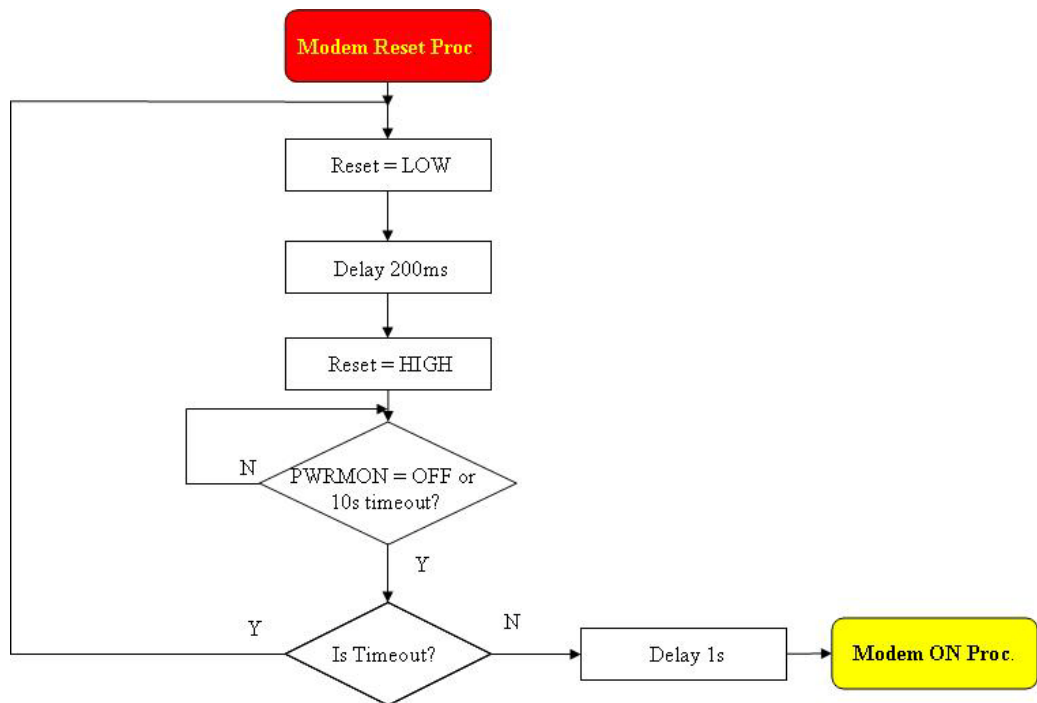



NOTE:

Do not use any pull up resistor on the RESET# line nor any totem pole digital output. Using pull up resistor may bring to latch up problems on the GM862 power regulator and improper functioning of the module. The line RESET# must be connected only in open collector configuration.



TIP:

The unconditional hardware restart must always be implemented on the boards and must be used by the software as an emergency exit procedure.

In the following flow chart is detailed the proper restart procedure:

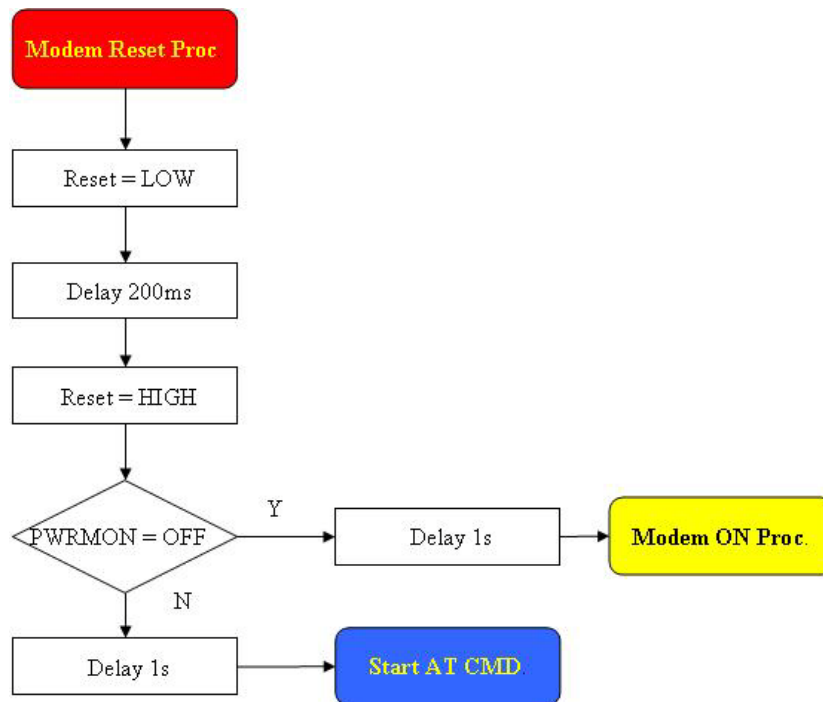

For example:

Let us assume you need to drive the RESET# pin with a totem pole output of a +3/5 V microcontroller (uP_OUT2):

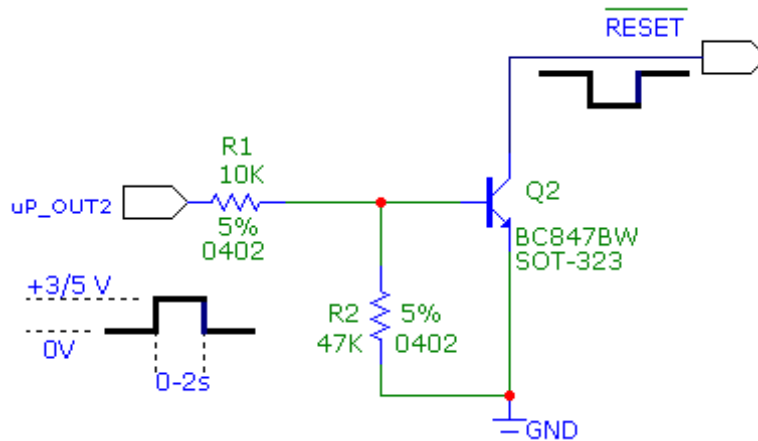

If device does not respond to a command in the timeout window, retry issuing the command and if still no response is received a hardware reset shall be issued.



The following table is describing the power consumptions of the module:

GM862-QUAD / GM862-QUAD-PY		
Mode	Average (mA)	Mode description
SWITCHED OFF		
Switched Off	<26 μ A	Module supplied but Switched Off
IDLE mode		
AT+CFUN=1	19.0	Normal mode: full functionality of the module
AT+CFUN=4	18.2	Disabled TX and RX; module is not registered on the network
AT+CFUN=0 or =5	6.6	Paging Multiframe 2
	4.5	Paging Multiframe 4
	3.3	Paging Multiframe 6
	3.2	Paging Multiframe 8
	2.5	Paging Multiframe 9
CSD TX and RX mode		
GSM900 CSD PL5	237.3	GSM VOICE CALL
DCS1800 CSD PL0	223.8	
GPRS (class 10) 1TX		
GSM900 PL5	264,0	GPRS Sending data mode
DCS1800 PL0	176,0	
GPRS (class 10) 2TX		
GSM900 PL5	473,8	GPRS Sending data mode
DCS1800 PL0	307,8	



The following table is describing the power consumptions of the module in case of the GE863-GPS:

GM862-GPS		
Mode	Average (mA)	Mode description
SWITCHED OFF		
Switched Off	<30 uA	Module supplied but Switched Off
IDLE mode (GPSP=0)		
AT+CFUN=1	19.0	Normal mode: full functionality of the module
AT+CFUN=4	18.2	Disabled TX and RX; module is not registered on the network
AT+CFUN=0 or =5	6.6	Paging Multiframe 2
	4.5	Paging Multiframe 4
	3.3	Paging Multiframe 6
	3.2	Paging Multiframe 8
	3.3	Paging Multiframe 9
IDLE mode (GPSP=1)		
AT+CFUN=1	79.4	Normal mode: full functionality of the module
AT+CFUN=4	79.0	Disabled TX and RX; module is not registered on the network
AT+CFUN=0 or =5	70.3	Paging Multiframe 2
	68.6	Paging Multiframe 4
	67.8	Paging Multiframe 6
	63.4	Paging Multiframe 8
	63.0	Paging Multiframe 9
IDLE mode (GPSPS=2,1800)		
AT+CFUN=0 or =5	11.5	Paging Multiframe 2
	10.0	Paging Multiframe 9
CSD TX and RX mode		
GSM900 CSD PL5	325.0	GSM VOICE CALL + GPS receiver active
DCS1800 CSD PL0	302.2	
GPRS (class 10) 1TX		
GSM900 PL5	264,0	GPRS Sending data mode
DCS1800 PL0	176,0	
GPRS (class 10) 2TX		
GSM900 PL5	473,8	GPRS Sending data mode
DCS1800 PL0	307,8	

RF transmission in GSM systems is not continuous, being packed into bursts at a base frequency of about 216 Hz. The relative current peaks can be as high as about 2A. The power supply has to be designed in order to withstand these current peaks without big voltage drops; this means that both the electrical design and the board layout must be designed for this current flow.





TIP:

The power supply electrical design must forecast a peak current output of at least 2A.

If the layout of the PCB is not properly designed, then a strong noise floor is generated on the ground and the supply; this reflects on all the audio paths producing an audible and annoying noise at 216 Hz; if the voltage drops, the overwhelming peak current absorption might cause the device to even shutdown, as a consequence of the supply voltage drop.

7.2. Embodied Battery Charger

The battery charger is suited for 3.7V Li-Ion rechargeable battery (suggested capacity 500-1000mAh). The Charger needs only a CURRENT LIMITED power source input and charges the battery directly through VBATT connector pins.

Battery charger input pin	CHARGE
Battery pins	VBATT, GND
Battery charger input voltage min	5.0 V
Battery charger input voltage typ	5.5 V
Battery charger input voltage max	7.0 V
Battery charger input current max	400mA
Battery type	Li-Ion rechargeable



NOTE:

If embodied battery charger is used, then a LOW ESR capacitor of at least 100µF must be mounted in parallel to VBATT pin.

NOTE:

When power is supplied to the CHARGE pin, a battery must always be connected to the VBATT pin of the GM862.



7.3. General Design Rules

The principal guidelines for the Power Supply Design embrace three different design steps:

- the electrical design
- the thermal design.
- the PCB layout.

7.3.1. Electrical Design Guidelines

The electrical design of the power supply depends strongly from the power source where this power is drained. We will distinguish them into three categories:

- +5V input (typically PC internal regulator output)
- +12V input (typically automotive)
- Battery

7.3.1.1. +5V input Source Power Supply Design Guidelines

The desired output for the power supply is 3.8V, hence there is not a big difference between the input source and the desired output and a linear regulator can be used. A switching power supply will not be suited because of the low drop out requirements.

When using a linear regulator, a proper heat sink shall be provided in order to dissipate the power generated.

A Bypass low ESR capacitor of adequate capacity must be provided in order to cut the current absorption peaks close to the GM862, a 100 μ F tantalum capacitor is usually suited.

Make sure the low ESR capacitor on the power supply output (usually a tantalum one) is rated at least 10V.

A protection diode must be inserted close to the power input, in order to save the GM862 from power polarity inversion.

An example of linear regulator with 5V input is:



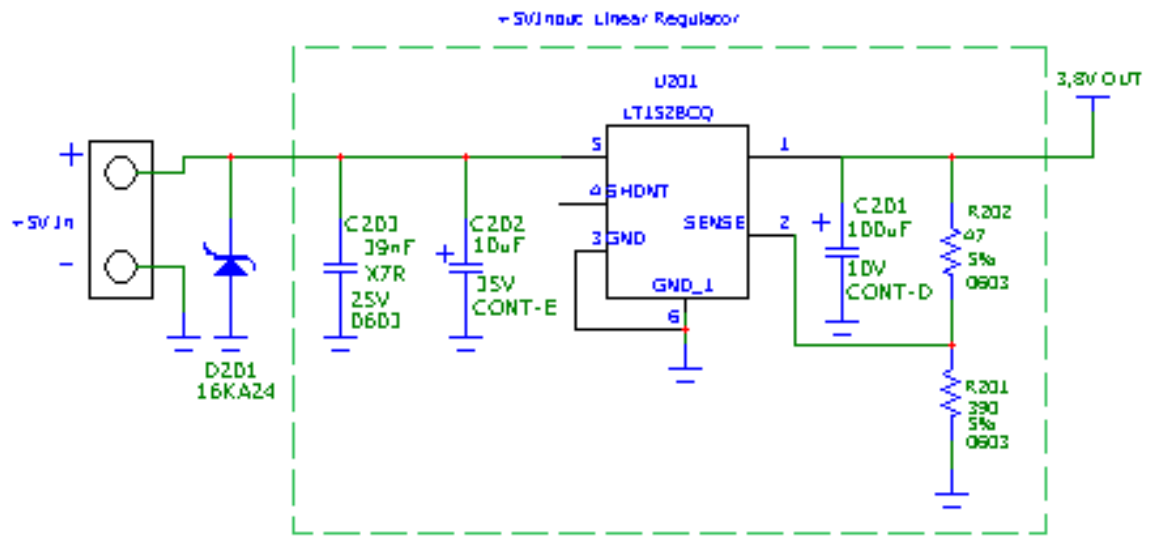

7.3.1.2. +12V Input Source Power Supply Design Guidelines

The desired output for the power supply is 3.8V, hence due to the big difference between the input source and the desired output, a linear regulator is not suited and shall not be used. A switching power supply will be preferable because of its better efficiency especially with the 2A peak current load represented by the GM862-GPS.

When using a switching regulator, a 500kHz or more switching frequency regulator is preferable because of its smaller inductor size and its faster transient response. This allows the regulator to respond quickly to the current peaks absorption.

In any case the frequency and Switching design selection is related to the application to be developed due to the fact the switching frequency could also generate EMC interferences.

For car PB battery the input voltage can rise up to 15,8V and this must be kept in mind when choosing components: all components in the power supply must withstand this voltage.

A Bypass low ESR capacitor of adequate capacity must be provided in order to cut the current absorption peaks, a 100 μ F tantalum capacitor is usually suited.

Make sure the low ESR capacitor on the power supply output (usually a tantalum one) is rated at least 10V.

For Car applications a spike protection diode must be inserted close to the power input, in order to clean the supply from spikes.



A protection diode must be inserted close to the power input, in order to save the GM862 from power polarity inversion. This can be the same diode as for spike protection.

An example of switching regulator with 12V input is in the below schematic (it is split in 2 parts):

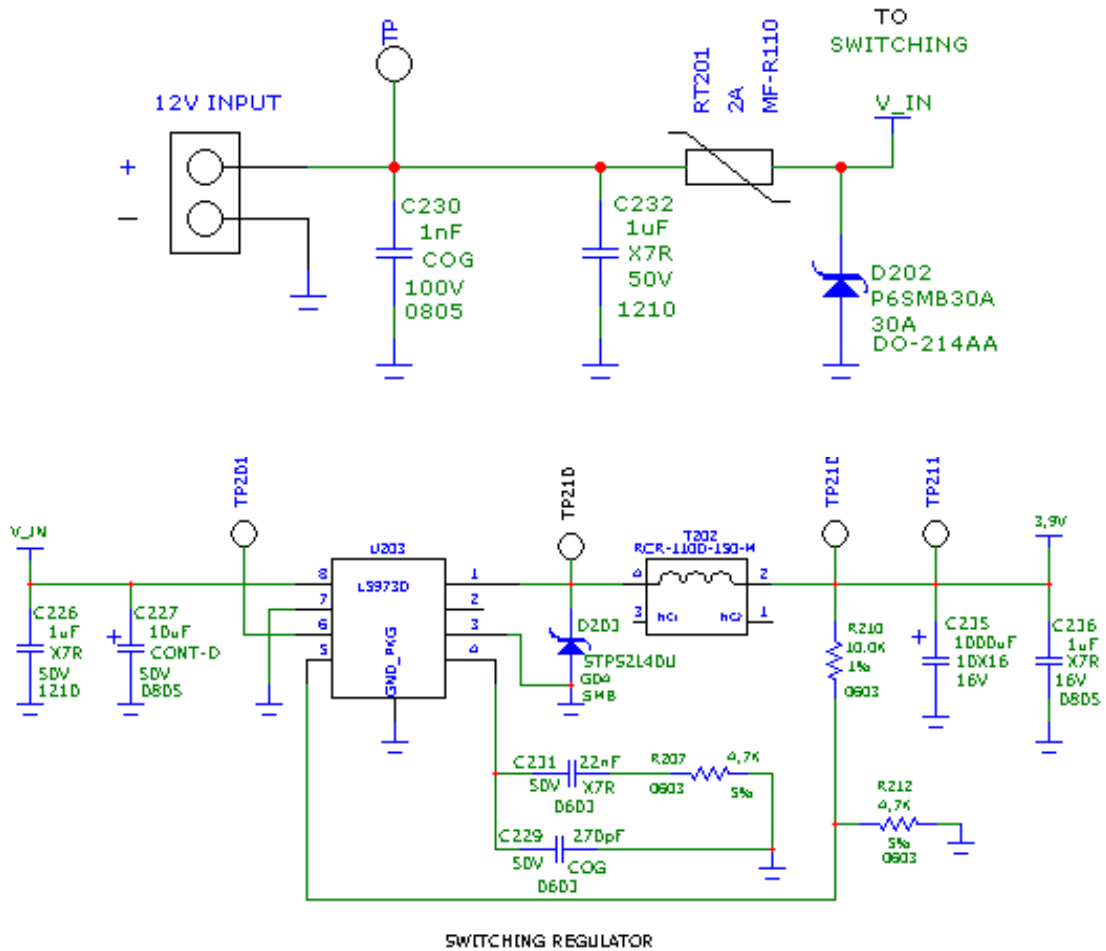

7.3.1.3. Battery Source Power Supply Design Guidelines

The desired nominal output for the power supply is 3.8V and the maximum voltage allowed is 4.2V (4.5 V if using SW release 7.03.x00 or newer), hence a single 3.7V Li-Ion cell battery type is suited for supplying the power to the Telit GM862 module.





CAUTION:

The three cells Ni/Cd or Ni/MH 3,6 V Nom. battery types or 4V PB types **MUST NOT BE USED DIRECTLY** since their maximum voltage can rise over the absolute maximum voltage for the GM862 and damage it.

CAUTION:

DO NOT USE any Ni-Cd, Ni-MH, and Pb battery types directly connected with GM862. Their use can lead to overvoltage on the GM862 and damage it. **USE ONLY Li-Ion** battery types.

A Bypass low ESR capacitor of adequate capacity must be provided in order to cut the current absorption peaks, a 100 μ F tantalum capacitor is usually suited.

Make sure the low ESR capacitor (usually a tantalum one) is rated at least 10V.

A protection diode must be inserted close to the power input, in order to save the GM862 from power polarity inversion. Otherwise the battery connector must be done in a way to avoid polarity inversions when connecting the battery.

The battery capacity must be at least 500mAh in order to withstand the current peaks of 2A; the suggested capacity is from 500mAh to 1000mAh.

7.3.1.4. Battery Charge Control Circuitry Design Guidelines

The charging process for Li-Ion Batteries can be divided into 4 phases:

- Qualification and trickle charging
- Fast charge 1 - constant current
- Final charge - constant voltage or pulsed charging
- Maintenance charge

The qualification process consists in a battery voltage measure, indicating roughly its charge status. If the battery is deeply discharged, that means its voltage is lower than the trickle charging threshold, then the charge must start slowly possibly with a current limited pre-charging process where the current is kept very low with respect to the fast charge value: the trickle charging.

During the trickle charging the voltage across the battery terminals rises; when it reaches the fast charge threshold level the charging process goes into fast charge phase.

During the fast charge phase the process proceeds with a current limited charging; this current limit depends on the required time for the complete charge and from the battery pack capacity. During this phase the voltage across the battery terminals still raises but at a lower rate.



Once the battery voltage reaches its maximum voltage then the process goes into its third state: Final charging. The voltage measure to change the process status into final charge is very important. It must be ensured that the maximum battery voltage is never exceeded, otherwise the battery may be damaged and even explode. Moreover for the constant voltage final chargers, the constant voltage phase (final charge) must not start before the battery voltage has reached its maximum value, otherwise the battery capacity will be highly reduced.

The final charge can be of two different types: constant voltage or pulsed. GM862 uses constant voltage.

The constant voltage charge proceeds with a fixed voltage regulator (very accurately set to the maximum battery voltage) and hence the current will decrease while the battery is becoming charged. When the charging current falls below a certain fraction of the fast charge current value, then the battery is considered fully charged, the final charge stops and eventually starts the maintenance.

The pulsed charge process has no voltage regulation, instead the charge continues with pulses. Usually the pulse charge works in the following manner: the charge is stopped for some time, let us say few hundreds of ms, then the battery voltage will be measured and when it drops below its maximum value a fixed time length charging pulse is issued. As the battery approaches its full charge the off time will become longer, hence the duty-cycle of the pulses will decrease. The battery is considered fully charged when the pulse duty-cycle is less than a threshold value, typically 10%, the pulse charge stops and eventually the maintenance starts.

The last phase is not properly a charging phase, since the battery at this point is fully charged and the process may stop after the final charge. The maintenance charge provides an additional charging process to compensate for the charge leak typical of a Li-Ion battery. It is done by issuing pulses with a fixed time length, again few hundreds of ms, and a duty-cycle around 5% or less.

This last phase is not implemented in the GM862 internal charging algorithm, so that the battery once charged is left discharging down to a certain threshold so that it is cycled from full charge to slight discharge even if the battery charger is always inserted. This guarantees that anyway the remaining charge in the battery is a good percentage and that the battery is not damaged by keeping it always fully charged (Li-Ion rechargeable battery usually deteriorate when kept fully charged).

Last but not least, in some applications it is highly desired that the charging process restarts when the battery is discharged and its voltage drops below a certain threshold, GM862 internal charger does it.

As you can see, the charging process is not a trivial task to be done; moreover all these operations must start only if battery temperature is inside a charging range, usually $5^{\circ}\text{C} \div 45^{\circ}\text{C}$.



The GM862 measures the temperature of its internal component, in order to satisfy this last requirement, it is not exactly the same as the battery temperature but in common application the two temperature must not differ too much and the charging temperature range must be guaranteed.



NOTE:

When starting the charger from Module powered off the startup will be in CFUN4; to activate the normal mode a command AT+CFUN=1 has to be provided.

NOTE:

For all the threshold voltages, inside the GM862 all threshold are fixed in order to maximize Li-Ion battery performances and do not need to be changed.

NOTE:

In this application the battery charger input current must be limited to less than 400mA. This can be done by using a current limited wall adapter as the power source.

NOTE:

When starting the charger from Module powered off the startup will be in CFUN4; to activate the normal mode a command AT+CFUN=1 has to be provided. There is also the possibility to activate the normal mode using the ON_OFF* signal.

In this case, when HW powering off the module with the same line (ON_OFF*) and having the charger still connected, the module will go back to CFUN4.

7.3.2. Thermal Design Guidelines

The thermal design for the power supply heat sink must be done with the following specifications:

- Average current consumption during transmission @PWR level max (rms): 500mA
- Average current consumption during transmission @ PWR level min (rms): 100mA
- Average current during Power Saving (CFUN=5): 4mA
- Average current during idle (Power Saving disabled): 24mA
- Average GPS current during Power Saving (GM862-GPS ONLY): 1mA
- Average GPS current during Tracking (Power Saving disabled) (GM862-GPS ONLY): 60mA





NOTE:

The average consumption during transmissions depends on the power level at which the device is requested to transmit by the network. The average current consumption hence varies significantly.



TIP:

The thermal design for the Power supply must be made keeping an average consumption at the max transmitting level during calls of 500mA rms.

Considering the very low current during idle, especially if Power Saving function is enabled, it is possible to consider from the thermal point of view that the device absorbs current significantly only during calls.

If we assume that the device stays into transmission for short periods of time (let us say few minutes) and then remains for a quite long time in idle (let us say one hour), then the power supply has always the time to cool down between the calls and the heat sink could be smaller than the calculated one for 500mA maximum RMS current, or even could be the simple chip package (no heat sink).

Moreover in the average network conditions the device is requested to transmit at a lower power level than the maximum and hence the current consumption will be less than the 500mA, being usually around 200mA.

For these reasons the thermal design is rarely a concern and the simple ground plane where the power supply chip is placed can be enough to ensure a good thermal condition and avoid overheating.

7.3.3. Power Supply PCB Layout Guidelines

As seen on the electrical design guidelines the power supply shall have a low ESR capacitor on the output to cut the current peaks and a protection diode on the input to protect the supply from spikes and polarity inversion. The placement of these components is crucial for the correct working of the circuitry. A misplaced component can be useless or can even decrease the power supply performances.

The Bypass low ESR capacitor must be placed close to the Telit GM862 power input pins or in the case the power supply is a switching type it can be placed close to the inductor to cut the ripple provided the PCB trace from the capacitor to the GM862 is wide enough to ensure a dropless connection even during the 2A current peaks.

The protection diode must be placed close to the input connector where the power source is drained.



The PCB traces from the input connector to the power regulator IC must be wide enough to ensure no voltage drops occur when the 2A current peaks are absorbed. Note that this is not made in order to save power loss but especially to avoid the voltage drops on the power line at the current peaks frequency of 216 Hz that will reflect on all the components connected to that supply, introducing the noise floor at the burst base frequency. For this reason while a voltage drop of 300-400 mV may be acceptable from the power loss point of view, the same voltage drop may not be acceptable from the noise point of view. If your application does not have audio interface but only uses the data feature of the Telit GM862, then this noise is not so disturbing and power supply layout design can be more forgiving.

The PCB traces to the GM862 and the Bypass capacitor must be wide enough to ensure no voltage drops occur when the 2A current peaks are absorbed. This is for the same reason as previous point. Try to keep this trace as short as possible.

The PCB traces connecting the Switching output to the inductor and the switching diode must be kept as short as possible by placing the inductor and the diode very close to the power switching IC (only for switching power supply). This is done in order to reduce the radiated field (noise) at the switching frequency (100÷500 kHz usually).

The use of a good common ground plane is suggested.

The placement of the power supply on the board must be done in such a way to guarantee that the high current return paths in the ground plane are not overlapped to any noise sensitive circuitry as the microphone amplifier/buffer or earphone amplifier.

The power supply input cables must be kept separate from noise sensitive lines such as microphone/earphone cables.



7.3.4. Parameters for ATEX Application

In order to integrate the Telit's GE862 module into an ATEX application, the appropriate reference standard IEC EN xx and integrations shall be followed.

Below are listed parameters and useful information to integrate the module in your application:

- GM862-QUAD & GM862-PY
 - Total capacity: 78.596 μ F
 - Total inductance: 10.383 μ H
- GM862-GPS
 - Total capacity: 83.167 μ F
 - Total inductance: 10.485 μ H
- No voltage upper than supply voltage is present in the module.
- No step-up converters are present in the module.
- In abnormal conditions, the maximum RF output power is 34 dBm for few seconds.

For this particular application, we recommend the customer to involve TTSC (Telit Technical Support Center) in the design phase of the application.



8. Serial Ports

8.1. GM862-GPS SERIAL PORTS

The serial port on the Telit GM862-GPS is the core of the interface between the module and OEM hardware.

2 serial ports are available on the module:

- MODEM SERIAL PORT
- GPS SERIAL PORT (NMEA)

8.2. GM862-QUAD/ QUAD-PY SERIAL PORTS

The serial port on the Telit GM862-QUAD/ QUAD-PY is the core of the interface between the module and OEM hardware.

2 serial ports are available on the module:

- MODEM SERIAL PORT
- TRACE (Usable only on GM862-QUAD-PY for Python Debug)

8.3. MODEM SERIAL PORT

Several configurations can be designed for the serial port on the OEM hardware, but the most common are:

- RS232 PC com port
- microcontroller UART @ 2.8V - 3V (Universal Asynchronous Receive Transmit)
- microcontroller UART@ 5V or other voltages different from 2.8V

Depending from the type of serial port on the OEM hardware a level translator circuit may be needed to make the system work. The only configuration that does not need a level translation is the 2.8V UART.



The MODEM serial port on the GM862 is a +2.8V UART with all the 7 RS232 signals. It differs from the PC-RS232 in the signal polarity (RS232 is reversed) and levels. The levels for the GM862 UART are the CMOS levels:

Absolute Maximum Ratings - Not Functional

Parameter	Min	Max
Input level on any digital pin when on	-0.3V	+3.6V
Input voltage on analog pins when on	-0.3V	+3.0 V

Operating Range - Interface levels (2.8V CMOS)

Level	Min	Max
Input high level VIH	2.1V	3.3V
Input low level VIL	0V	0.5V
Output high level VOH	2.2V	3.0V
Output low level VOL	0V	0.35V

The signals of the GM862 MODEM serial port are:

RS232 Pin Number	Signal	GM862 Pin Number	Name	Usage
1	DCD - dcd_uart	36	Data Carrier Detect	Output from the GM862 that indicates the carrier presence
2	RXD - tx_uart	37	Transmit line *see Note	Output transmit line of GM862 UART
3	TXD - rx_uart	20	Receive line *see Note	Input receive of the GM862 UART
4	DTR - dtr_uart	43	Data Terminal Ready	Input to the GM862 that controls the DTE READY condition
5	GND	2-4	Ground	Ground
6	DSR - dsr_uart	33	Data Set Ready	Output from the GM862 that indicates the module is ready
7	RTS - rts_uart	45	Request to Send	Input to the GM862 that controls the Hardware flow control
8	CTS - cts_uart	29	Clear to Send	Output from the GM862 that controls the Hardware flow control
9	RI - ri_uart	30	Ring Indicator	Output from the GM862 that indicates the incoming call condition





NOTE:

According to V.24, RX/TX signal names are referred to the application side, therefore on the GM862 side these signal are on the opposite direction: TXD on the application side will be connected to the receive line (here named TXD/ rx_uart) of the GM862 serial port and viceversa for RX.

TIP:

For a minimum implementation, only the TXD and RXD lines can be connected, the other lines can be left open provided a software flow control is implemented.



8.4. GPS SERIAL PORT (GM862-GPS only)

The signals of the GPS serial port are:

Signal	GM862-GPS Pin Number	Name	Usage
RX_GPS	41	GPS Receive line	Input line of GPS serial Port (NMEA protocol)
TX_GPS	35	GPS Transmit line	Output line of GPS serial Port (NMEA protocol)
GND	2-4	Ground	Ground

The default configuration is 4800 bps, 8, n, 1

GPS RX Lines and TX lines may need a dual supply isolation buffer like an FXLP34 to avoid CMOS high states while in POWER SAVING.

8.5. TRACE SERIAL PORT (GM862-QUAD-PY only)

The signals of the TRACE serial port are:

Signal	GM862-QUAD- PY Pin Number	Name	Usage
RX_TRACE	41	Python Debug Receive line	Input line of Python Debug serial Port
TX_TRACE	35	Python Debug Transmit line	Output line of Python Debug serial Port
GND	2-4	Ground	Ground

8.6. Level Translation

In order to interface the Telit GM862 with a PC com port or a RS232 (EIA/TIA-232) application a level translator is required. This level translator must

- invert the electrical signal in both directions
- change the level from 0/3V to +15/-15V

Actually, the RS232 UART 16450, 16550, 16650 & 16750 chipsets accept signals with lower levels on the RS232 side (EIA/TIA-562), allowing for a lower voltage-multiplying ratio on the level translator. Note that the negative signal voltage must be less than 0V and hence some sort of level translation is always required.

The simplest way to translate the levels and invert the signal is by using a single chip level translator. There are a multitude of them, differing in the number of driver and receiver and in the levels (be sure to get a true RS232 level translator not a RS485 or other standards).

By convention the driver is the level translator from the 0-3V UART level to the RS232 level, while the receiver is the translator from RS232 level to 0-3V UART.



In order to translate the whole set of control lines of the UART you will need:

- 5 driver
- receiver



NOTE:

The digital input lines working at 2.8VCMOS have an absolute maximum input voltage of 3,6V; therefore the level translator IC shall not be powered by the +3.8V supply of the module. Instead it shall be powered from a +2.8V / +3.0V (dedicated) power supply.

This is because in this way the level translator IC outputs on the module side (i.e. GM862 inputs) will work at +3.8V interface levels, stressing the module inputs at its maximum input voltage.

An example of level translation circuitry of this kind is:

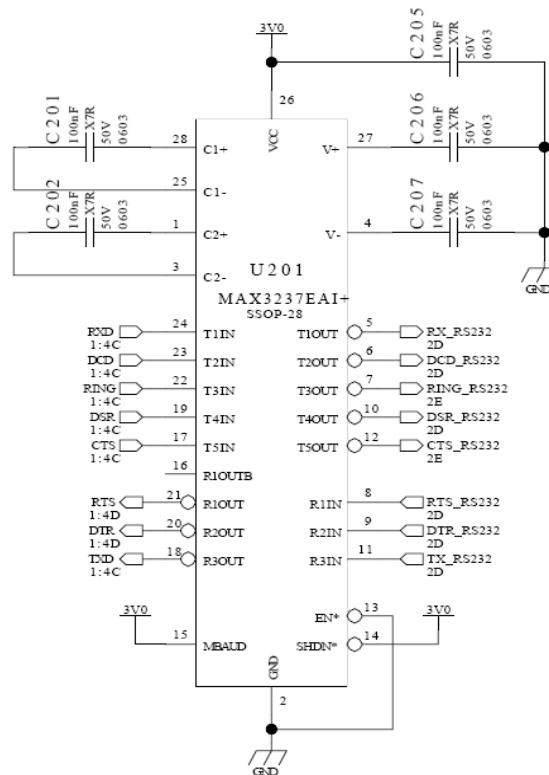

RS232 LEVEL TRSANSULATOR



The RS232 serial port lines are usually connected to a DB9 connector with the following layout:

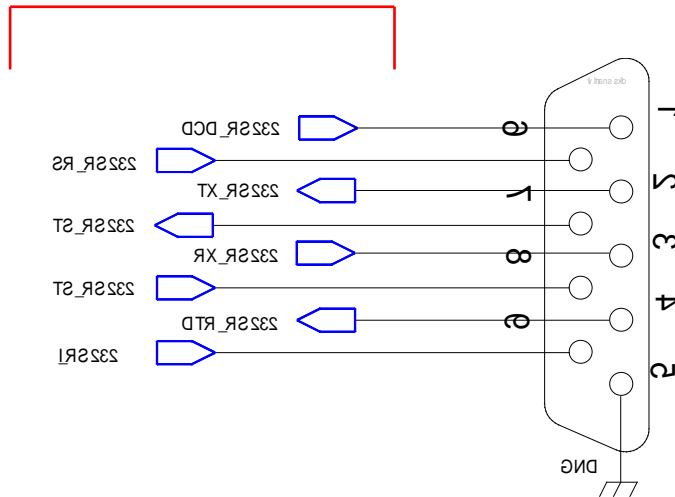

8.7. 5V UART Level Translation

If the OEM application uses a microcontroller with a serial port (UART) that works at a voltage different from 2.8 - 3V, then a circuitry has to be provided to adapt the different levels of the two set of signals. As for the RS232 translation there are a multitude of single chip translators. For example a possible translator circuit for a 5V TRANSMITTER/RECEIVER can be:



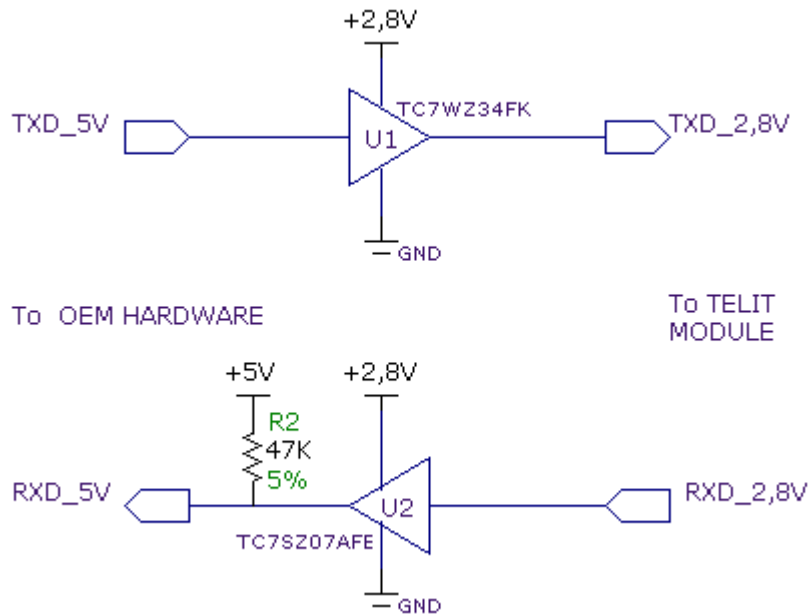

TIP:

This logic IC for the level translator and 2.8V pull-ups (not the 5V one) can be powered directly from PWRMON line of the GM862. Note that the TC7SZ07AE has open drain output, therefore the resistor R2 is mandatory.



NOTE:

The UART input line TXD (rx_uart) of the GM862S is NOT internally pulled up with a resistor, so there may be the need to place an external 47K Ω pull-up resistor, either the DTR (dtr_uart) and RTS (rts_uart) input lines are not pulled up internally, so an external pull-up resistor of 47K Ω may be required.

A power source of the internal interface voltage corresponding to the 2.8VCMOS high level is available at the PWRMON pin on the connector, whose absolute maximum output current is 1mA.

A maximum of 9 resistors of 47K Ω pull-up can be connected to the PWRMON pin, provided no other devices are connected to it and the pulled-up lines are GM862 input lines connected to open collector outputs in order to avoid latch-up problems on the GM862.

Care must be taken to avoid latch-up on the GM862 and the use of this output line to power electronic devices shall be avoided, especially for devices that generate spikes



and noise such as switching level translators, micro controllers, failure in any of these condition can severely compromise the GM862 functionality.



NOTE:

The input lines working at 2.8VCMOS can be pulled-up with 47K Ω resistors that can be connected directly to the PWRMON line provided they are connected as in this example.

NO OTHER devices than those suggested must be powered with the PWRMON line; otherwise the module functionality may be compromised.

It is important to consider that the added circuit must have consumption lower than 1mA.

In case of reprogramming of the module has to be considered the use of the RESET line to start correctly the activity.

The preferable configuration is having an external supply for the buffer.



9. Audio Section Overview

The Baseband chip was developed for the cellular phones, which needed two separated amplifiers both in RX and in TX section.

A couple of amplifiers had to be used with internal audio transducers while the other couple of amplifiers had to be used with external audio transducers.

To distinguish the schematic signals and the Software identifiers, two different definitions were introduced, with the following meaning:

- internal audio transducers → *HS/MT* (from HandSet or MicroTelephone)
- external audio transducers → *HF* (from HandsFree)

Actually the acronyms have not the original importance.

In other words this distinction is not necessary, being the performances between the two blocks like the same.

Only if the customer needs higher output power to the speaker, he has a constraint. Otherwise the choice could be done in order to overcome the PCB design difficulties.

For these reasons we have not changed the HS and HF acronyms, keeping them in the Software and on the schematics.

The Base Band Chip of the GM862 Telit Module maintains the same architecture.

For more information refer to Telit document:

“ 80000NT10007a Audio Settings Application Note ”.

9.1. Selection mode

Only one block can be active at a time, and the activation of the requested audio path is done via hardware by AXE line or via software by ***AT#CAP*** command.

Moreover the Sidetone functionality could be implemented by the amplifier fitted between the transmit path and the receive path, enabled at request in both modes.



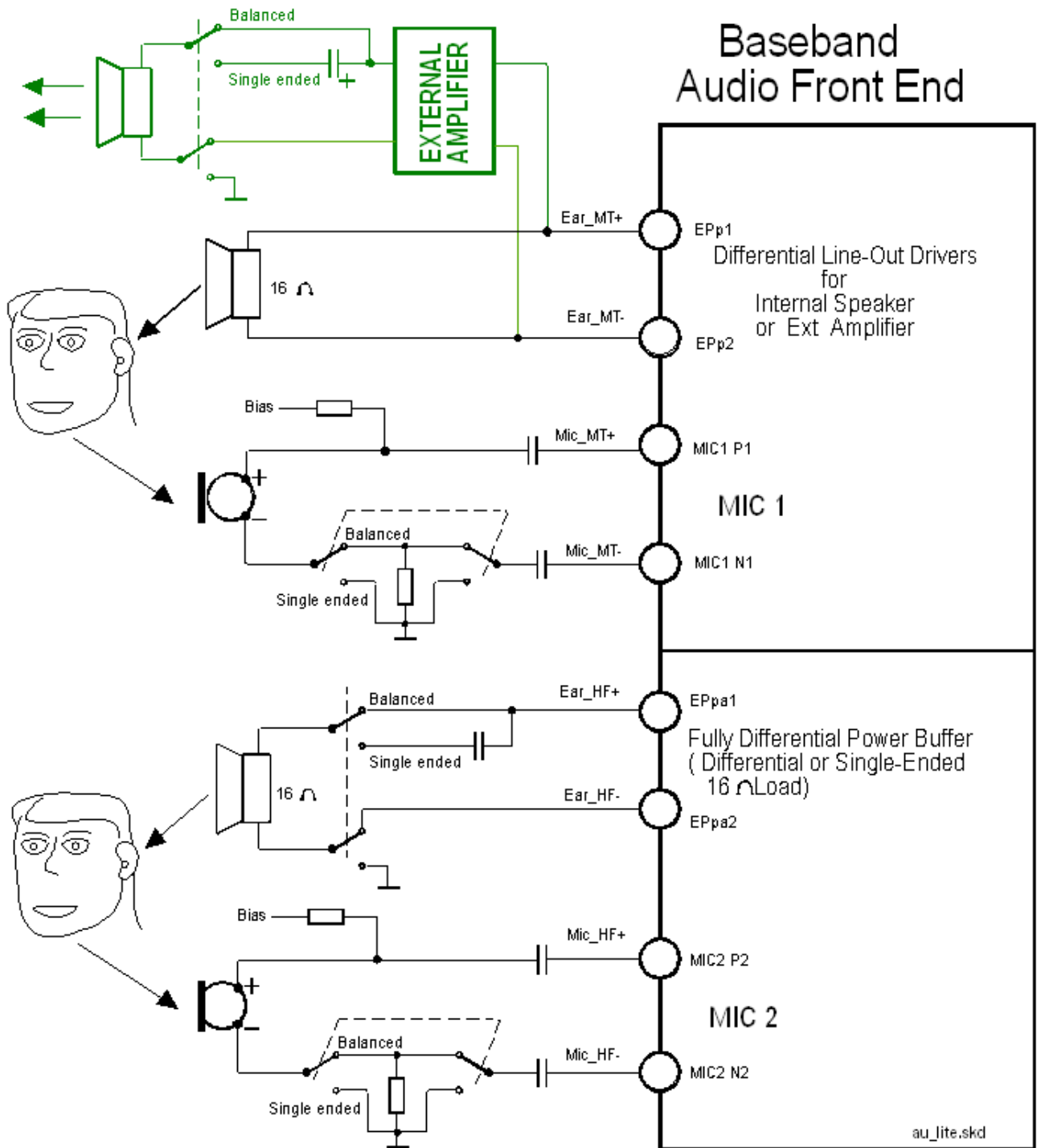

Audio Section Block Diagram



9.2. Electrical Characteristics



TIP:

Being the microphone circuitry the more noise sensitive, its design and layout must be done with particular care. Both microphone paths are balanced and the OEM circuitry must be balanced designed to reduce the common mode noise typically generated on the ground plane. However the customer can use the unbalanced circuitry for particular application.

9.3. Input Lines Characteristics

"MIC_MT" and "MIC_HF" differential microphone paths	
Line Coupling	AC *
Line Type	Balanced
Coupling capacitor	100nF
Differential input resistance	50K
Differential input voltage	1,03Vpp @ MicG=0dB



(*) WARNING:

AC means that the signals from the microphone have to be connected to input lines of the module through a capacitors which value has to be 100nF.

Not respecting this constraint, the input stages will be damaged.



WARNING:

When particular OEM application needs a *Single Ended Input* configuration, it is forbidden connecting the unused input directly to Ground, but only through a 100nF capacitor.

Don't forget that in Single Ended configuration the useful input signal will be halved.



9.4. Output Lines Characteristics



TIP:

We suggest driving the load differentially from both output drivers, thus the output swing will double and the need for the output coupling capacitor avoided. However if particular OEM application needs also a Single Ended circuitry can be implemented, but the output power will be reduced four times.

The OEM circuitry shall be designed to reduce the common mode noise typically generated on the ground plane and to get the maximum power output from the device (low resistance tracks).



WARNING:

The loads are directly connected to the amplifier outputs when in Differential configuration, through a capacitor when in Single Ended configuration.

Using Single Ended configuration, the unused output line must be left open. Not respecting this constraint, the output stage will be damaged.



TIP:

Remember that there are slightly different electrical performances between the two internal audio amplifiers:

- the “*Ear_MT*” lines can directly drive a **16Ω load** at -12dBFS (**) in *Differential* configuration
- the “*Ear_HF*” lines can directly drive a **16Ω load** in *Differential* or *Single Ended* configurations

There is no difference if the amplifiers drive an external amplifier

()** *0dBFS* is the normalized overall Analog Gain for each Output channel equal to $3,7V_{pp}$ differential



"EAR_MT" Output Lines		
line coupling	single-ended	AC
	differential	DC
output load resistance		$\geq 14 \Omega$
internal output resistance		4Ω (typical)
signal bandwidth		150 ÷ 4000 Hz @ -3dB
max. differential output voltage		$1.31 V_{rms}$ (typical, open circuit)
differential output voltage		$328 mV_{rms} / 16 \Omega / @ -12dBFS$
volume increment		2 dB per step
volume steps		10

"EAR_HF" Output Lines		
line coupling:	single-ended	AC
	differential	DC
output load resistance :		$\geq 14 \Omega$
internal output resistance:		$4 \Omega (>1,7 \Omega)$
signal bandwidth:		150 ÷ 4000 Hz @ -3dB
max. differential output voltage		$1.31 V_{rms}$ (typical, open circuit)
max. S.E. output voltage		$656 mV_{rms}$ (typical, open circuit)
volume increment		2 dB per step
volume steps		10



10. General Purpose I/O

The general-purpose I/O pins can be configured to act in three different ways:

- input
- output
- alternate function (internally controlled)

The following GPIO are available on the GM862:

Pin	Signal	I/O	Function	Type	Input / output current	Default State	ON_OFF state	State during Reset	Note
34	GPI1	I	GPI01 Configurable GPIO	CMOS 2.8V	1uA / 1mA	INPUT	0		
28	GPO2	O	GPO02 Configurable GPIO	CMOS 2.8V	1uA / 1mA	OUTPUT	0		Open Collector Alternate function (JDR)
46	GPI03	I/O	GPI003 Configurable GPIO	CMOS 2.8V	1uA / 1mA	INPUT	1	1	47K Pull Up
47	GPI04	I/O	GPI004 Configurable GPIO	CMOS 2.8V	1uA / 1mA	INPUT	1	1	4.7K Pull Up Alternate function (RF Transmission Control)
48	GPI05	I/O	GPI005 Configurable GPIO	CMOS 2.8V	1uA / 1mA	INPUT	0		Alternate function (RFTXMON)
49	GPI06	I/O	GPI006 Configurable GPIO	CMOS 2.8V	1uA / 1mA	INPUT	fig. 01	1	Alternate function (ALARM)
50	GPI07	I/O	GPI007 Configurable GPIO	CMOS 2.8V	1uA / 1mA	INPUT	0		Alternate function (BUZZER)
32	GPI08	I/O	GPI008 Configurable GPIO	CMOS 2.8V	1uA / 1mA	INPUT	0		



34	GPIO9	I/O	GPIO09 Configurable GPIO	CMOS 2.8V	1uA / 1mA	INPUT	0		
38	GPIO10	I/O	GPIO10 Configurable GPIO	CMOS 2.8V	1uA / 1mA	INPUT	0		
40	GPIO11	I/O	GPIO11 Configurable GPIO	CMOS 2.8V	1uA / 1mA	INPUT	1	1	4.7K Pull Up
42	GPIO12	I/O	GPIO12 Configurable GPIO	CMOS 2.8V	1uA / 1mA	INPUT	1	1	47K Pull Up
44	GPIO13	I/O	GPIO13 Configurable GPIO	CMOS 2.8V	1uA / 1mA	INPUT	0		

Input pins can only be read and report the digital value (high or low) present on the pin at the read time; output pins can only be written or queried and set the value of the pin output; an alternate function pin is internally controlled by the GM862 firmware and acts depending on the function implemented.

Not all GPIO pins support all these three modes:

- GPIO1 is an INPUT ONLY
- GPIO2 is an OUTPUT ONLY (open collector)
- GPIO3, GPIO8 to GPIO13 support both input or output mode but not Alternate function.
- GPIO4 supports all three modes and can be input, output, RF Transmission Control (Alternate function)
- GPIO5 supports all three modes and can be input, output, RFTXMON output (Alternate function)
- GPIO6 supports all three modes and can be input, output, ALARM output (Alternate function)
- GPIO7 supports all three modes and can be input, output, BUZZER output (Alternate function)



All GPIO pins except from GPIO1 and GPIO2 that are buffered with a transistor, are 2.8V CMOS signals.

ch1: ON_OFF (2sec)
ch2: GPIO 06 [bis]

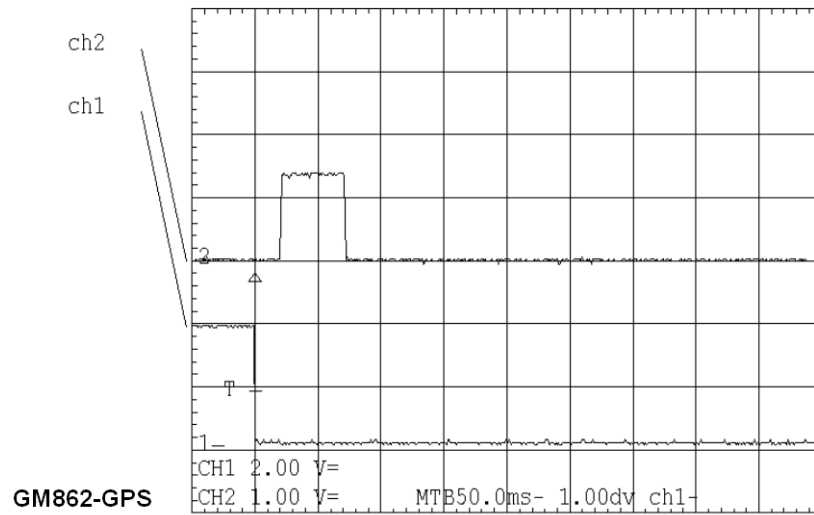

10.1. GPIO Logic Levels

Where not specifically stated, all the interface circuits work at 2.8V CMOS logic levels.

The following table shows the logic level specifications used in the GM862 interface circuits:

Absolute Maximum Ratings -Not Functional

Parameter	Min	Max
Input level on any digital pin when on	-0.3V	+3.6V
Input voltage on analog pins when on	-0.3V	+3.0 V

Operating Range - Interface levels (2.8V CMOS)

Level	Min	Max
Input high level	2.1V	3.3V
Input low level	0V	0.5V
Output high level	2.2V	3.0V
Output low level	0V	0.35V

Operating Range - Interface levels (1.8V CMOS)

Level	Min	Max
Input high level	1.6V	2.2V
Input low level	0V	0.4V
Output high level	1,65V	2.2V
Output low level	0V	0.35V



10.2. Using a GPIO Pin as INPUT

The GPIO pins, when used as inputs, can be connected to a digital output of another device and report its status, provided this device has interface levels compatible with the 2.8V CMOS levels of the GPIO.

If the digital output of the device to be connected with the GPIO input pin has interface levels different from the 2.8V CMOS, then it can be connected to GPIO1 or can be buffered with an open collector transistor, provided with a 47K Ω pull-up resistor to 2.8V.

10.3. Using a GPIO Pin as OUTPUT

The GPIO pins, when used as outputs, can drive 2.8V CMOS digital devices or compatible hardware. When set as outputs, the pins (except from GPIO2 which is Open Collector) have a push-pull output and therefore the pull-up resistor may be omitted.

The illustration below shows the base circuit of a push-pull stage:

The GPIO2 pin, since it is an Open Collector output needs an external pull-up resistor.

10.4. Using the RF Transmission Control GPIO4

The GPIO4 pin, when configured as RF Transmission Control Input, permits to disable the Transmitter when the GPIO is set to Low by the application.

10.5. Using the RFTXMON Output GPIO5

The GPIO5 pin, when configured as RFTXMON Output, is controlled by the GM862-

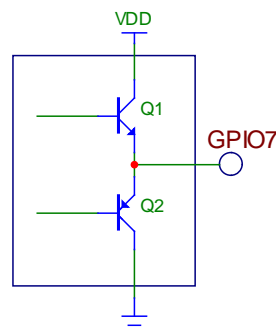

GPS module and will rise when the transmitter is active and fall after the transmitter activity is completed.



For example, if a call is started, the line will be HIGH during all the conversation and it will be again LOW after hanged up.

The line rises up 300ms before first TX burst and will become again LOW from 500ms to 1sec after last TX burst.

10.6. Using the Alarm Output GPIO6

The GPIO6 pin, when configured as Alarm Output, is controlled by the GM862 module and will rise when the alarm starts and fall after the issue of a dedicated AT command.

This output can be used to power up the GM862 controlling microcontroller or application at the alarm time, giving you the possibility to program a timely system wake-up to achieve some periodic actions and completely turn off either the application and the GM862 during sleep periods, dramatically reducing the sleep consumption to few μA .

In battery powered devices this feature will greatly improve the autonomy of the device.



NOTE:

During RESET the line is set to HIGH logic level.



10.7. Using the Buzzer Output GPIO7

The GPIO7 pin, when configured as Buzzer Output, is controlled by the GM862 module and will drive with appropriate square waves a Buzzer driver.

This permits to your application to easily implement Buzzer feature with ringing tones or melody played at the call incoming, tone playing on SMS incoming or simply playing a tone or melody when needed by your application. A sample interface scheme is included below to give you an idea of how to interface a Buzzer to the GPIO7:

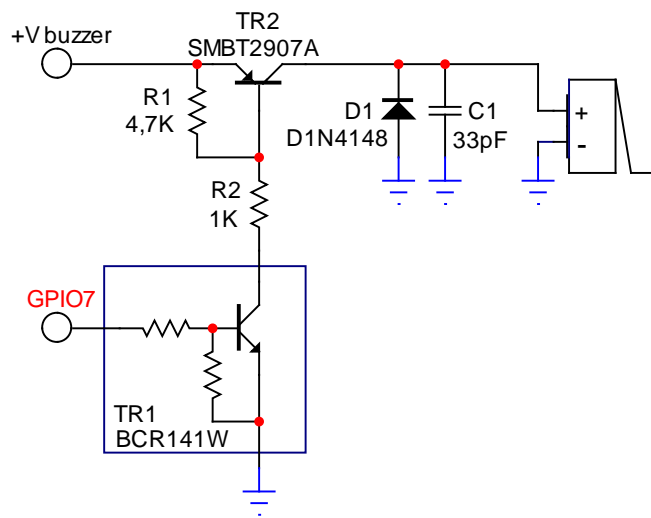

Example of Buzzer driving circuit.



NOTE:

To correctly drive a buzzer a driver must be provided, its characteristics depend on the Buzzer and for them refer to your buzzer vendor.



10.8. Magnetic Buzzer Concepts

10.8.1. Short Description

A magnetic Buzzer is a sound-generating device with a coil located in the magnetic circuit consisting of a permanent magnet, an iron core, a high permeable metal disk and a vibrating diaphragm.

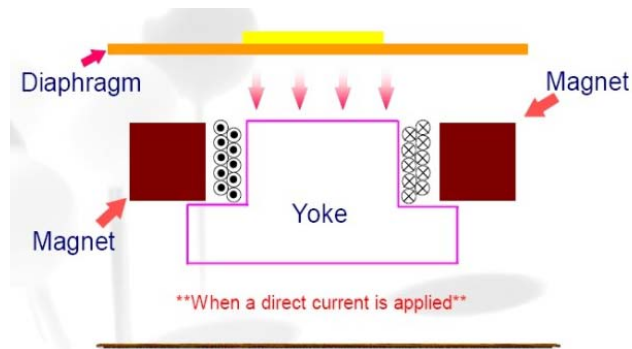

Drawing of the Magnetic Buzzer.

The disk and diaphragm are attracted to the core by the magnetic field. When an oscillating signal is moved through the coil, it produces a fluctuating magnetic field which vibrates the diaphragm at a frequency of the drive signal. Thus the sound is produced relative to the frequency applied.

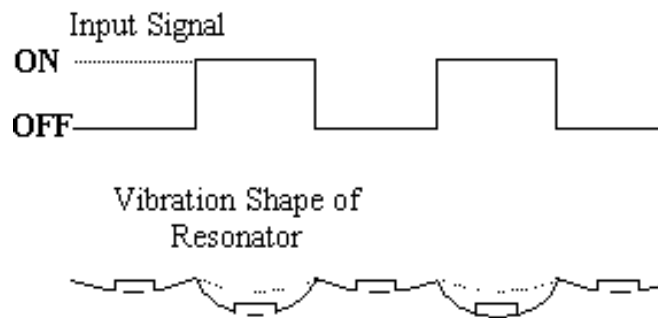

Diaphragm movement.



10.8.2. Frequency Behavior

The frequency behavior represents the effectiveness of the reproduction of the applied signals. Because performance is related to a square driving waveform (whose amplitude varies from 0V to V_{pp}), if you modify the waveform (e.g. from square to sinus) the frequency response will change.

10.8.3. Power Supply Influence

Applying a signal whose amplitude is different from that suggested by the manufacturer, the performance change following the rule “if resonance frequency f_o increases, amplitude decreases”.

Because resonance frequency depends on acoustic design, by lowering the amplitude of the driving signal the response bandwidth tends to become narrow, and vice versa.

Summarizing: $V_{pp} \uparrow \rightarrow f_o \downarrow$ $V_{pp} \downarrow \rightarrow f_o \uparrow$



WARNING:

It is very important to respect the sense of the applied voltage: never apply to the “-” pin a voltage more positive than the “+” pin: if this happens, the diaphragm vibrates in the opposite direction with a high probability to be expelled from its physical position. This damages the device permanently.

The risk is that the f_o could easily fall outside of new bandwidth; consequently the SPL could be much lower than the expected.

10.8.4. Working Current Influence

In the component data sheet you will find the value of MAX CURRENT: this represents the maximum average current that can flow at nominal voltage without current limitation. In other words it is not the peak current, which could be twice or three times higher. If driving circuitry does not support these peak values, the SPL will never reach the declared level or the oscillations will stop.



11. ADC Section

11.1. ADC Converter

11.1.1. Description

The GM862 module provides one Analog to Digital Converter. The input line (named ADC_IN1) is available on Pin #6 of the Module's connector of the module and on pin 19 of PL103 on EVK2 Board.

The on board A/D is 11-bit converter. It is able to read a voltage level in the range of 0÷2 volts applied on the ADC pin input, store and convert it into 11 bit word.

	Min	Max	Units
Input Voltage range	0	2	Volt
AD conversion	-	11	bits
Resolution	-	< 1	mV

11.1.2. Using ADC Converter

The AT command below is available to use the ADC function:

AT#ADC=1,2

The read value is expressed in mV.

Refer to SW user guide or to GM862 AT commands specification for the full description of this function.



12. Indication of Network Service Availability

The STAT_LED pin status shows information on the network service availability and Call status. The pin is an Open Collector output where it is possible to directly connect a LED to show information on the network service availability and Call status.

Therefore, the status indicated in the following table is reversed with respect to the pin status.

LED status	Blinking period	Ton	Device Status
permanently off	-----	---	device off
fast blinking	1s	0,5s	Net search / Not registered / turning off
slow blinking	3s	0,3s	Registered full service
permanently on	-----	---	a call is active



13. Mounting the GM862 Module on the Board

In order to electrically connect your board to the Telit GM862 modules, use a CSTP 2x25 pin vertical SMD SCH-SCH Molex 53748 - 0504 (female, low profile) as a counterpart to the CSTP 50 pin vertical SMD Molex 52991-0508 (male) of your Telit GM86.

When mounting the Telit GM862 on your board, take care of soldering the GM862 shielding reeds on a ground plane or signal.

Molex 53748-0504 (female, low profile) Connector LAY-OUT

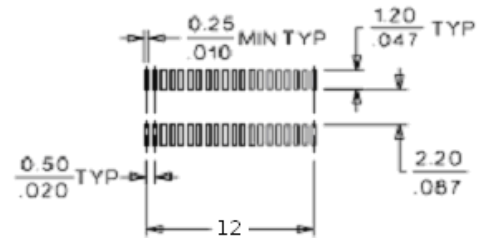
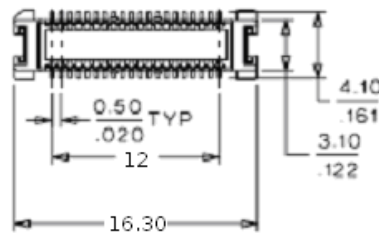
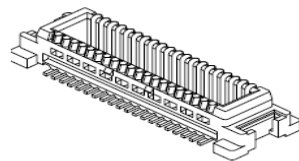

PCB LAYOUT: COMPONENT SIDE

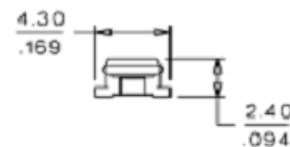

NOTE:

Be very careful when connecting the Telit GM862 module RF connector. The Telit GM862 module RF connector can be damaged if not connected with the proper antenna RF connector. The minimum number of insertion cycles is recommended.



13.1. Antenna Coaxial Cable Fixing

The following constraints must be respected in the Telit GM862 modules antenna cable connection:

- The fixing point of the coaxial cable must not be placed too close to the antenna connector of the GM862 module, leaving at least 30mm of flexible cable between the fixed point and the plug end.
- The fixing point must be at the same height of the GM862 module antenna connector, eventually using a wedge between the PCB and the cable if it is directly fixed to the PCB.
- The flexible cable must never be bent with a radius lower than 25mm (RG174 cable).
- The cable must be a RG174 type or more flexible ones.

The following pictures explain these constraints:

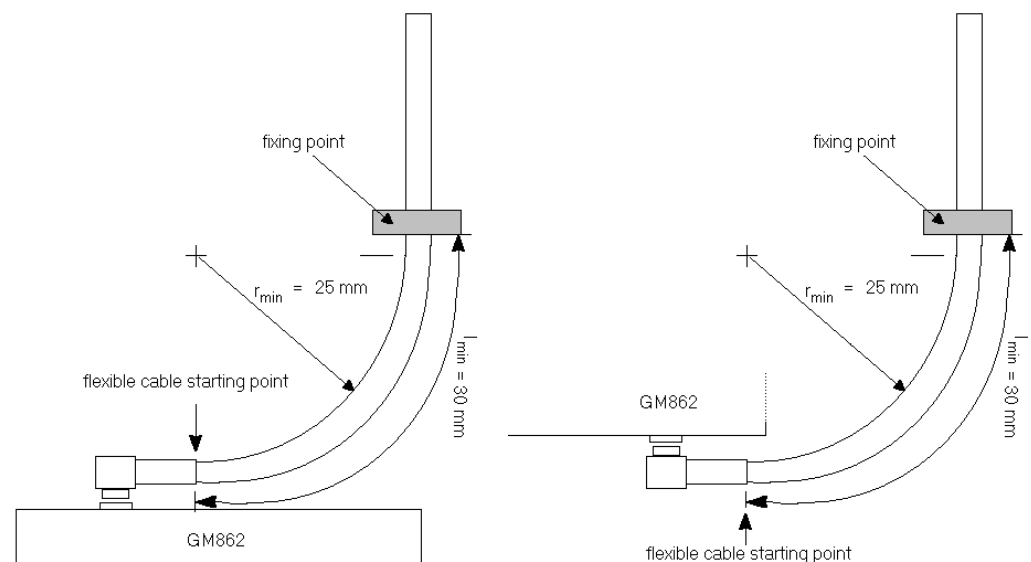

NOTE:

in the examples the cable is always bent, this is not a constrain. If the installation does not require it, then the cable can be kept straight, ensuring that the fixing is without sliding.



13.2. Precautions

The plug must be inserted in the connector only after the installation of the Telit GM862 modules in the board. This is to prevent accidental breaking of the antenna connection during the transport.

The coaxial cable must be fixed at least in one point, without sliding possibilities.

The plug insertion/removal must be done axially with the female connector of the GM862, keeping lateral strains to a minimum.

The insertion/crimping pull out force must be less than 15N.

The Hole's diameter for GM862 shielding reed soldering is: (1.5 ± 0.05) mm.



14. Conformity Assessment Issues

The Telit **GM862** has been assessed in order to requirements of the R&TTE Directive 1999/05/EC (Radio Telecommunications Terminal Equipments) to conformity against the harmonised standards with the Notified Body.

CE 0168

If the module is installed in conformance to the Telit installation manuals, no further evaluation under **Article 3.2** of the R&TTE Directive and do not require further involvement of a R&TTE Directive Notified Body for the final product.

In all other cases, or if the manufacturer of the final product is in doubt, then the equipment integrating the radio module must be assessed against **Article 3.2** of the R&TTE Directive.

In all cases the assessment of the final product must be made against the Essential requirements of the R&TTE Directive **Articles 3.1(a)** and **(b)**, Safety and EMC respectively, and any relevant Article 3.3 requirements.

This Product Description, the Hardware User Guide and Software User Guide contain all the information you may need for developing a product meeting the R&TTE Directive. Furthermore the **GM862** module is FCC Approved as module to be installed in other devices. This device is to be used only for fixed and mobile applications. If the final product after integration is intended for portable use, a new application and FCC is required.

The **GM862** is conforming to the following US Directives:

- Use of RF Spectrum. Standards: FCC 47 Part 24 (GSM 1900)
- EMC (Electromagnetic Compatibility). Standards: FCC47 Part 15

This device complies with Part 15 of the FCC Rules. Operation is subject to the following two conditions:

- (1) this device may not cause harmful interference, and
- (2) this device must accept any interference received, including interference that may cause undesired operation.

To meet the FCC's RF exposure rules and regulations:

- The system antenna(s) used for this transmitter must be installed to provide a separation distance of at least 20 cm from all the persons and must not be co-located or operating in conjunction with any other antenna or transmitter.
- The system antenna(s) used for this module must not exceed 1.4dBi (850MHz) and 3.0dBi (1900MHz) for mobile and fixed or mobile operating configurations.
- Users and installers must be provided with antenna installation instructions and transmitter operating conditions for satisfying RF exposure compliance.

Manufacturers of mobile, fixed or portable devices incorporating this module are advised to clarify any regulatory questions and to have their complete product tested and approved for FCC compliance.



15. SAFETY RECOMMENDATIONS



NOTE:

Read this section carefully to ensure the safe operation.

Be sure the use of this product is allowed in the country and in the environment required. The use of this product may be dangerous and has to be avoided in the following areas:

- Where it can interfere with other electronic devices in environments such as hospitals, airports, aircrafts, etc
- Where there is risk of explosion such as gasoline stations, oil refineries, etc

It is responsibility of the user to enforce the country regulation and the specific environment regulation.

Do not disassemble the product; any mark of tampering will compromise the warranty validity.

We recommend following the instructions of the hardware user guides for a correct wiring of the product. The product has to be supplied with a stabilized voltage source and the wiring has to be conforming to the security and fire prevention regulations.

The product has to be handled with care, avoiding any contact with the pins because electrostatic discharges may damage the product itself. Same cautions have to be taken for the SIM, checking carefully the instruction for its use. Do not insert or remove the SIM when the product is in power saving mode.

The system integrator is responsible of the functioning of the final product; therefore, care has to be taken to the external components of the module, as well as of any project or installation issue, because the risk of disturbing the GSM network or external devices or having impact on the security. Should there be any doubt, please refer to the technical documentation and the regulations in force.

Every module has to be equipped with a proper antenna with specific characteristics. The antenna has to be installed with care in order to avoid any interference with other electronic devices and has to guarantee a minimum distance from the body (20 cm). In case of this requirement cannot be satisfied, the system integrator has to assess the final product against the SAR regulation.



The European Community provides some Directives for the electronic equipments introduced on the market. All the relevant information's are available on the European

Community website:

<http://ec.europa.eu/enterprise/sectors/rtte/documents/>

The text of the Directive 99/05 regarding telecommunication equipments is available, while the applicable Directives (Low Voltage and EMC) are available at:

<http://ec.europa.eu/enterprise/sectors/electrical/>

